

# VICARIO<sup>®</sup>

S.R.L.



DESIGN E QUALITA' PER AMBIENTI DI PREGIO

Design and quality for precious ambiances



Il brand VICARIO® nasce nel 1973 a Borgomanero (Novara), dove tutt'ora ha sede lo stabilimento produttivo. Al suo interno, grazie all'intuito ed alla capacità imprenditoriale del fondatore Pier Carlo Vicario, nel corso degli anni, hanno preso vita progetti innovativi, che hanno migliorato l'efficienza e l'affidabilità delle soluzioni per il bagno e per la cucina.

Più di 50 anni di esperienza ci caratterizzano per le innovative soluzioni e proposte per l'ambiente bagno e cucina che coniugano praticità e design.

L'ampia gamma di prodotti firmati Vicario Srl continua ad arricchirsi di nuove collezioni, tutte personalizzabili nei minimi dettagli, per soddisfare tutte le diverse esigenze di funzionalità e di arredamento.

La costante ricerca tecnologica che caratterizza Vicario Srl, la pone, oggi, in una posizione di rilievo nel mercato europeo e mondiale.

Inoltre, la nostra produzione, si distingue anche per gli scarichi per vasca e piatti doccia, per le piantane supporto rubinetti, per le canaline di scarico per doccia, per i rubinetti sotto lavabo, per il sifoname e per la sempre più ampia serie di aste doccia, soffioni ed accessori doccia all'insegna della praticità, del comfort e dello stile.

Il valore aggiunto della Vicario Srl è la possibilità di una completa personalizzazione delle proprie soluzioni con design, misure e differenti finiture studiate ad hoc per il Cliente.

Un team esperto e dedicato di specialisti dei bagni è a disposizione per fornire un servizio di prima classe. Abbiamo riunito un team eccezionale, dai designer ai progettisti specializzati.

Ogni parte della nostra attività è stata attentamente considerata per fornire la migliore esperienza ai nostri clienti. Monitoriamo le innovazioni, le tecnologie e le tendenze globali nel nostro settore e continuiamo a istruire e formare per garantire che il nostro team rimanga al vertice della propria professione.

The brand VICARIO, founded in 1973 in Borgomanero (Novara), where the production plant is still located. Inside, thanks to the intuition and entrepreneurial ability of the founder Pier Carlo Vicario, over the years, innovative projects have come to life, which have improved the efficiency and reliability of bathroom and kitchen solutions.

More than 50 years of experience characterize us for the innovative solutions and proposals for the bathroom and kitchen that combine practicality and design.

The wide range of products by Vicario Srl continues to be enriched with new collections, all customizable in detail, to meet the different needs of functionality and furniture.

The constant technological research that characterizes Vicario Srl, puts it, today, in a prominent position in the European and world market.

In addition, our production also stands out for the drains for bath and shower trays, for the support stands taps, for the drain channels for shower, for the taps under the sink, for the siphons and for the increasingly wide series of shower rods, showerheads and shower accessories in the name of practicality, comfort and style.

The added value of Vicario Srl is the possibility of a complete customization of its solutions with design, sizes and different finishes designed ad hoc for the customer.

An experienced and dedicated team of bathroom specialists is available to provide a first class service. We have assembled an exceptional team, from designers to specialized designers.

Every part of our business has been carefully considered to provide the best experience to our customers. We monitor global innovations, technologies and trends in our industry and continue to educate and train to ensure that our team remains at the top of its profession.

INDICE  
INDEX

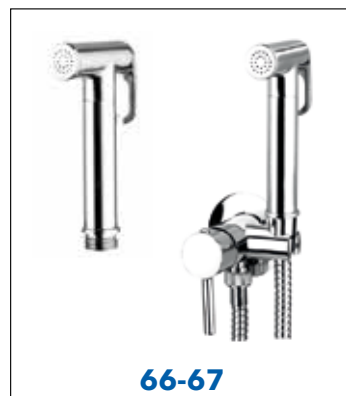
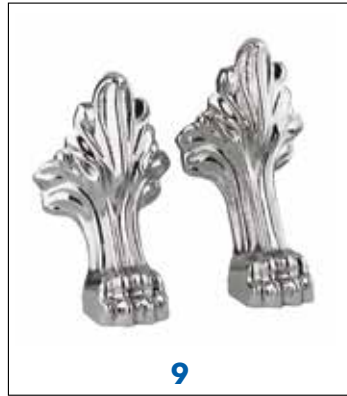
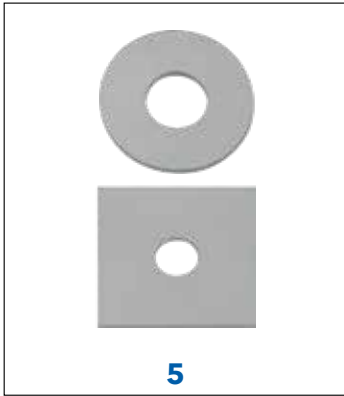



**76-77**



**80-83**



**84-95**



**97**



**99-105**



**107**



**108-112**



**113**



**114-115**



**116-117**



**118-119**



**120-122**

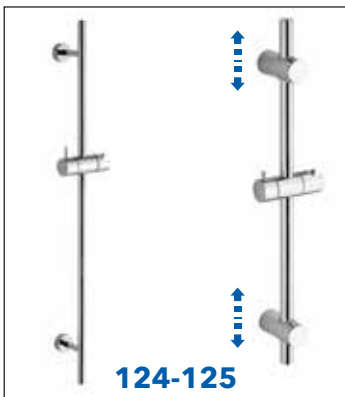

**124-125**



**128-137**



**138-146**



**148-149**



**151-157**

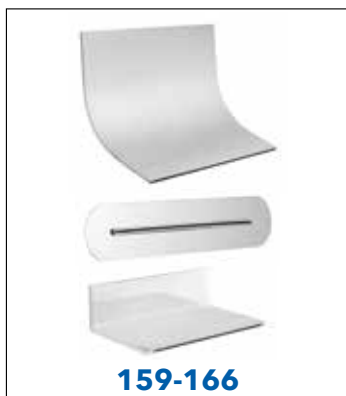

**159-166**



**168-174**



## MARCATURA LASER LASER ENGRAVING



VICARIO SRL offre il servizio di incisione laser con il quale si ha possibilità di applicare su tutti i nostri prodotti un logo personalizzato, un codice alfanumerico, un lotto di produzione o qualsiasi altro dato su richiesta

VICARIO SRL offers the laser engraving service which it is possible to apply a personalized logo, an alphanumeric code, a production lot or any other data on request to all our products

## TAGLIO LASER LASER CUTTING

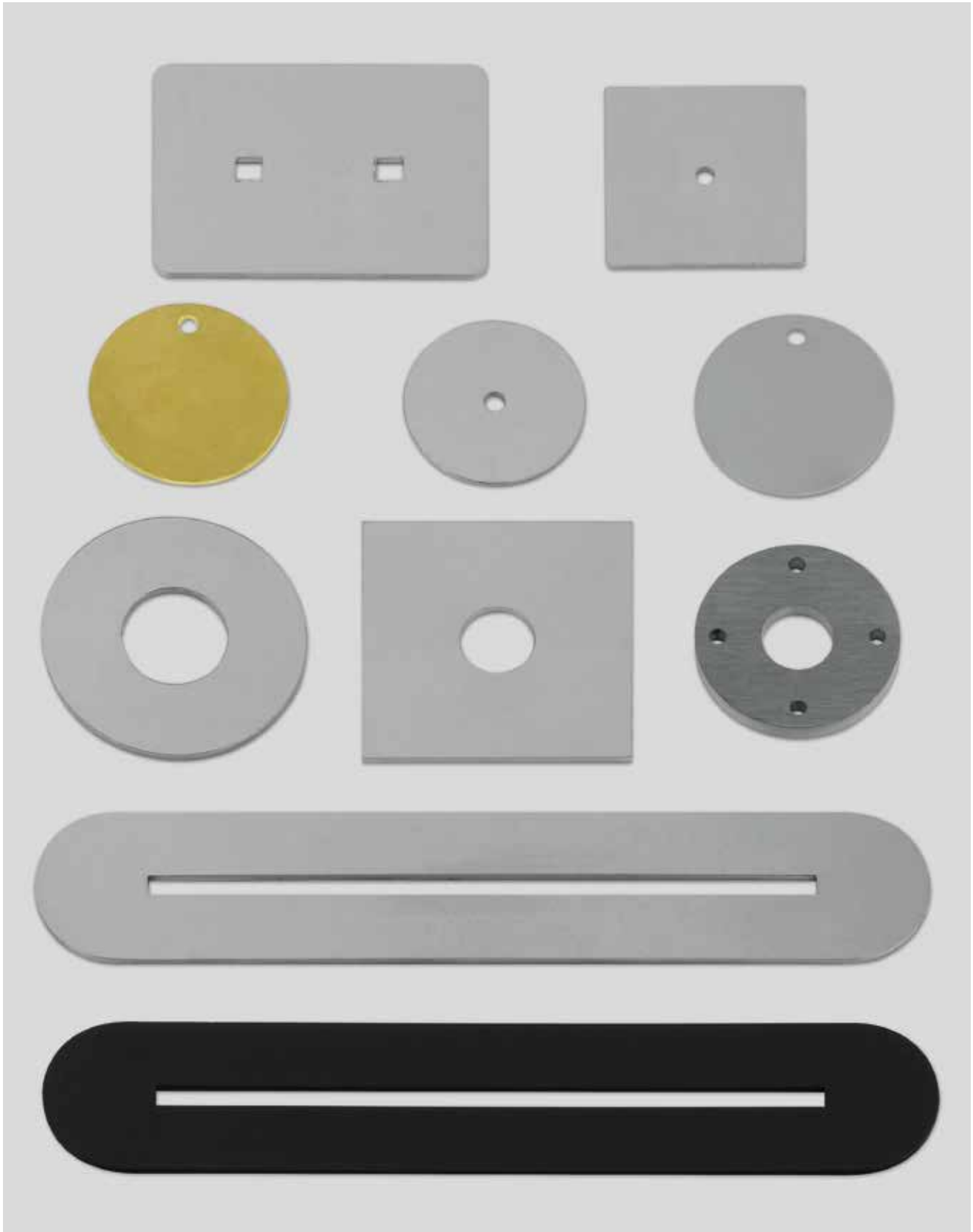

Grazie alla nuova tecnologia di taglio laser produciamo piastre personalizzate in acciaio inossidabile e in ottone in tutte le dimensioni e finiture

Thanks to the new laser cutting technology, we produce customized stainless steel and brass plates in all sizes and in all finishes

## FINITURE STANDARD STANDARD FINISHINGS

**Cod. 00**  
Ottone naturale  
senza protezione  
Natural brass without protection



**Cod. 07**  
Nickel spazzolato  
Brushed stainless steel

**Cod. 01**  
Cromo  
Chrome



**Cod. 08**  
Cromo nero  
Black chrome

**Cod. 02**  
Bronzo  
Bronze



**Cod. 17**  
Oro spazzolato  
Brushed gold

**Cod. 03**  
Rame  
Copper



**Cod. 50**  
Bianco opaco  
Matt white

**Cod. 04**  
Oro  
Gold



**Cod. 51**  
Bianco lucido  
Shiny white

**Cod. 05**  
Ottone protetto  
Natural brass with protection



**Cod. 55**  
Nero opaco  
Matt black

**Cod. 06**  
Oro rosa  
Pink gold



**Cod. 56**  
Nero lucido  
Shiny black

Altre finiture disponibili su richiesta  
Other finishings available on demand



# SCARICHI VASCA

Pop-up bathtub wastes





## STAFFE E PIEDINI PER VASCA BRACKETS AND FEET FOR BATHTUB

### ST-L

Staffa grande per supporto vasca

Large support bracket for bathtub

### ST-C

Staffa piccola per supporto vasca

Small support bracket for bathtub



### ZL/28

Piedino H28 cm Mod. ZAMPA DI LEONE  
completo di viterie di fissaggio

Bathtub foot H28 cm Mod. LION PAW  
complete with fixing screws



### ZL/31

Piedino H31 cm Mod. ZAMPA DI LEONE  
completo di viterie di fissaggio

Bathtub foot H31 cm Mod. LION PAW  
complete with fixing screws

### FINITURE - FINISHINGS

- Cromo - Chrome
- Bronzo - Bronze
- Rame - Copper
- Oro - Gold
- Oro rosa - Pink gold
- Nickel spazzolato - Brushed nickel
- Bianco opaco - Matt white
- Nero opaco - Matt black

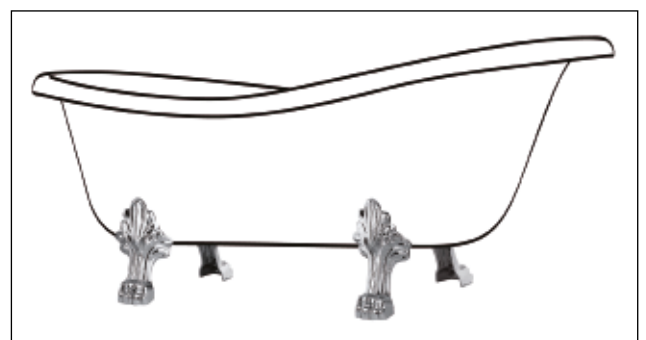
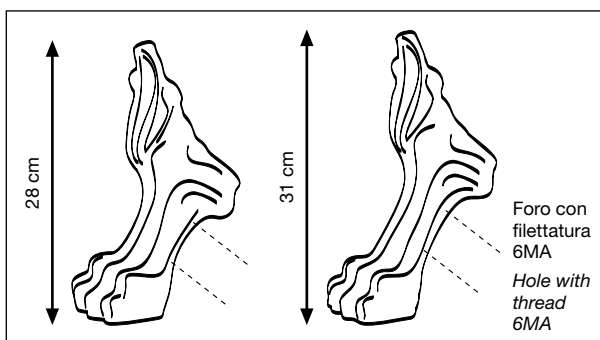

## PIANTANE FLOOR PILLARS

### 1050

Piantana a pavimento Mod. STANDARD  
con staffa a T di supporto

Floor pillar Mod. STANDARD  
with T support bracket

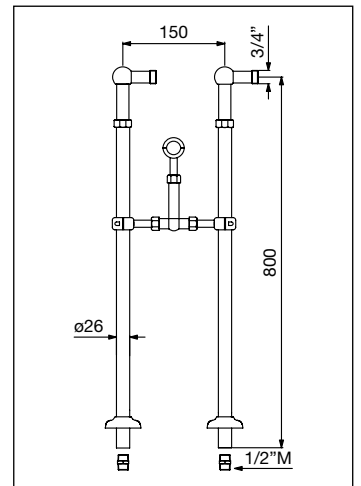

### 1049

Piantana a pavimento Mod. STANDARD  
con portadoccetta orientabile

Floor pillar Mod. STANDARD  
with orientable handshower support

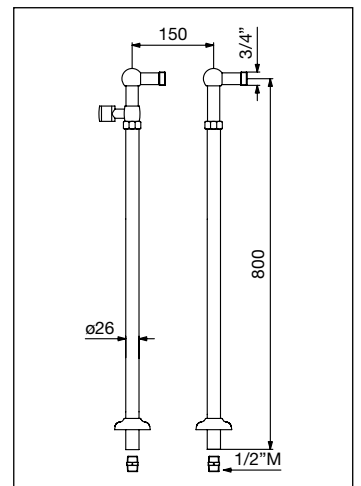

### 1052

Piantana a pavimento Mod. STANDARD  
senza portadoccetta

Floor pillar Mod. STANDARD  
without handshower support

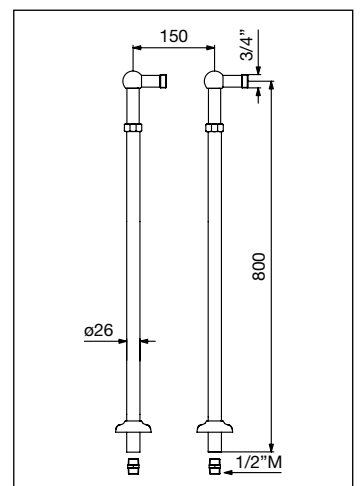

## PIANTANE FLOOR PILLARS

### 1051

Piantana a pavimento Mod. MINIMALISTA  
con portadoccetta orientabile

Floor pillar Mod. MINIMALIST  
with orientable handshower support

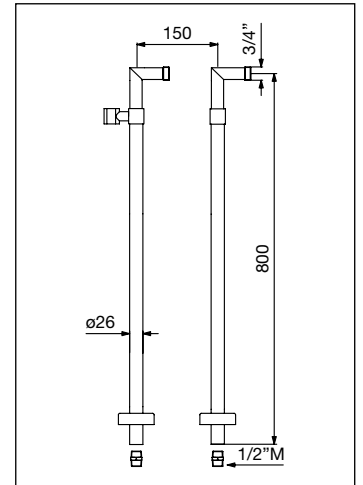

### 1051/SP

Piantana a pavimento Mod. MINIMALISTA  
senza portadoccetta

Floor pillar Mod. MINIMALIST  
without handshower support

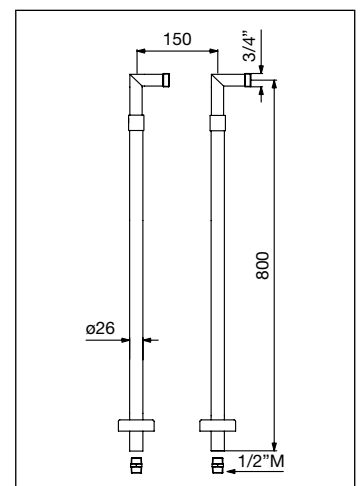

## PIANTANE FLOOR PILLARS

### 1053

Piantana a pavimento Mod. CURVO  
con rosette retrò senza portadoccetta

Floor pillar Mod. CURVED  
with old style rosettes without  
handshower support

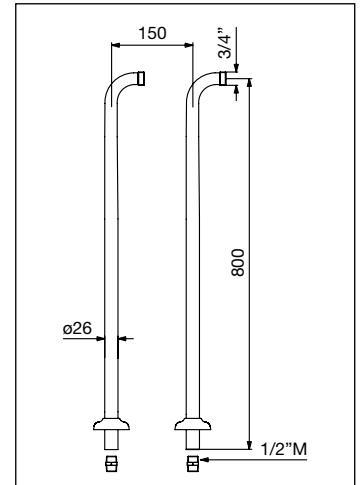
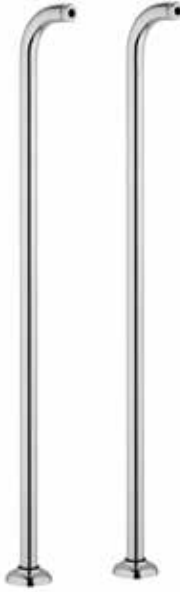

### 1054

Piantana a pavimento Mod. CURVO  
con rosette retrò con portadoccetta

Floor pillar Mod. CURVED  
with old style rosettes with  
handshower support

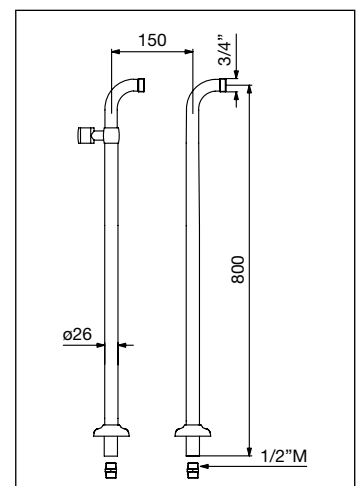

## PIANTANE FLOOR PILLARS

### 1055

Piantana a pavimento Mod. CURVO  
con rosette moderne senza portadoccia

Floor pillar Mod. CURVED  
with modern rosettes without hanshower support

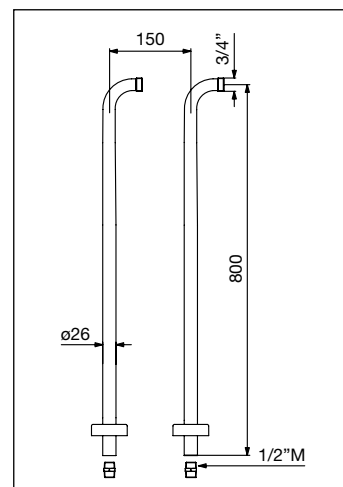
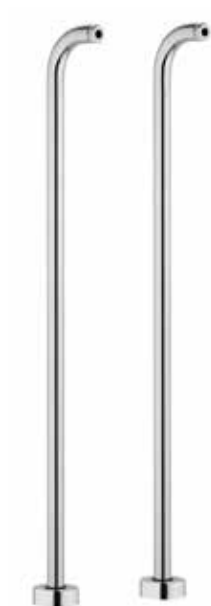

### 1056

Piantana a pavimento Mod. CURVO  
con rosette moderne con portadoccia

Floor pillar Mod. CURVED  
with modern rosettes with hanshower support

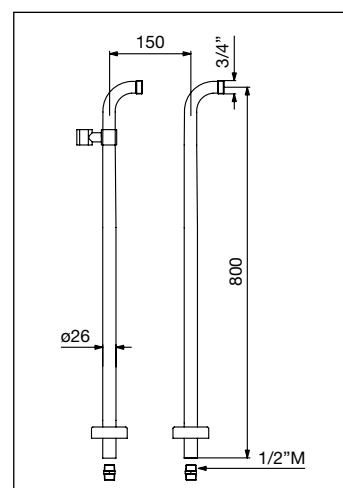

## SCARICHI PER VASCA A VISTA DRAINS FOR EXPOSED BATHTUB

### 1200

Scarico vasca a vista in ottone con tappo e catenella, completo di sifone  
- Tubo troppo pieno 108°

Brass drain for exposed bathtub with plug and chain, complete with trap  
- Overflow pipe 108°

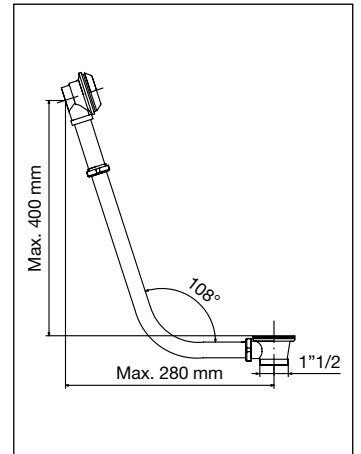

### 1210

Scarico vasca a vista in ottone con tappo CLICK-CLACK, completo di sifone  
- Tubo troppo pieno 108°

Brass drain for exposed bathtub with CLICK-CLACK plug, complete with trap  
- Overflow pipe 108°

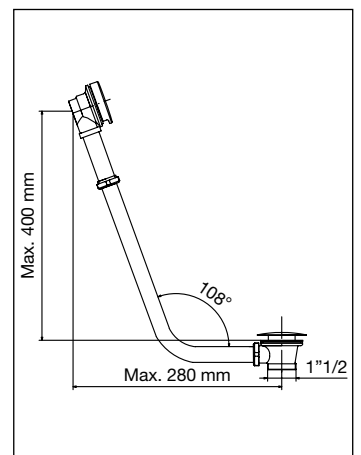
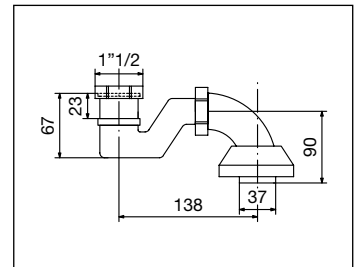

## SCARICHI PER VASCA A VISTA DRAINS FOR EXPOSED BATHTUB

### 1200/L

Scarico vasca a vista in ottone con tappo e catenella, completo di sifone  
- Tubo troppo pieno 95°

Brass drain for exposed bathtub with plug and chain, complete with trap  
- Overflow pipe 95°

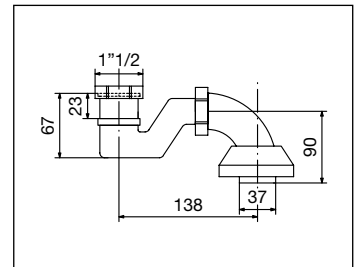
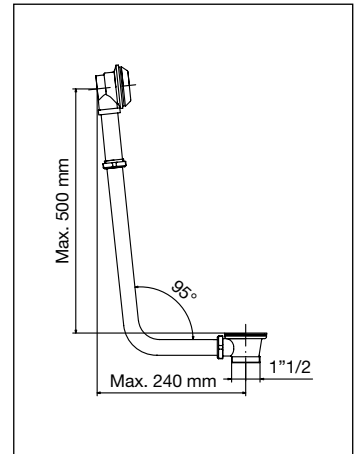

### 1210/L

Scarico vasca a vista in ottone con tappo CLICK-CLACK, completo di sifone  
- Tubo troppo pieno 95°

Brass drain for exposed bathtub with CLICK-CLACK plug, complete with trap  
- Overflow pipe 95°

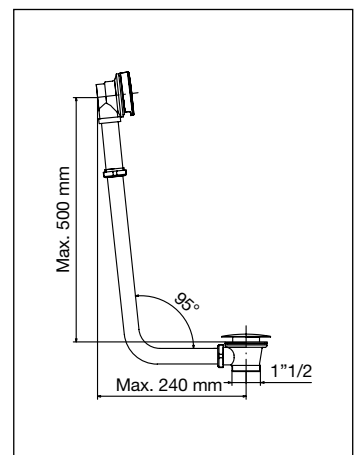



## ACCESSORI PER SCARICHI A VISTA EXPOSED DRAINS ACCESSORIES

### 029/1200

Snodo di regolazione tubo troppo pieno  
per scarichi a vista

Overflow pipe adjustment joint  
for exposed drains

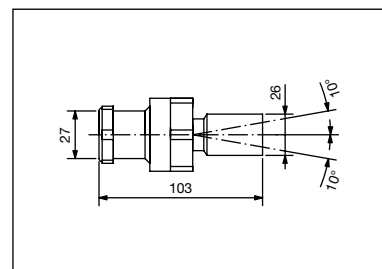

### 800/1200

Sifone in ottone per vasche a vista

Brass trap for exposed bathtubs

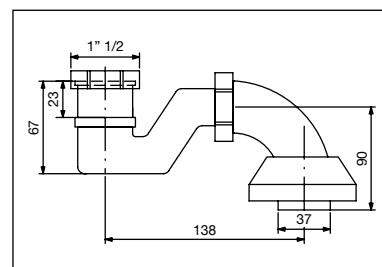

### 821

Estensione regolabile per sifone a vista

Adjustable extension for exposed trap

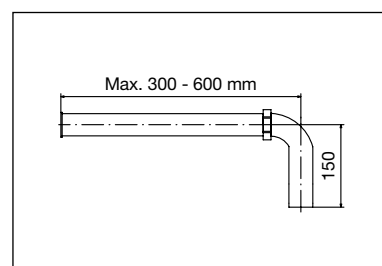

### Versioni disponibili - Available versions

Codice Code	Dimensioni Dimensions
821/300	Max 300 mm
821/600	Max 600 mm

## SCARICHI CLICK-CLACK A VISTA EXPOSED CLICK-CLACK DRAINS

### 1016

Scarico vasca CLICK-CLACK universale a vista, per vasca senza troppo pieno o con troppo pieno integrato

Universal exposed CLICK-CLACK drain, for bathtub without overflow or with integrated overflow

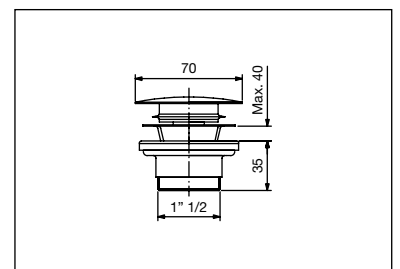
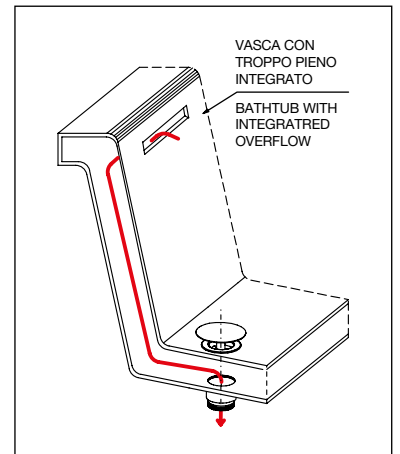

### 1016/817

Scarico vasca CLICK-CLACK universale a vista completo di sifone, per vasca senza troppo pieno o con troppo pieno integrato

Universal exposed CLICK-CLACK drain complete with trap, for bathtub without overflow or with integrated overflow

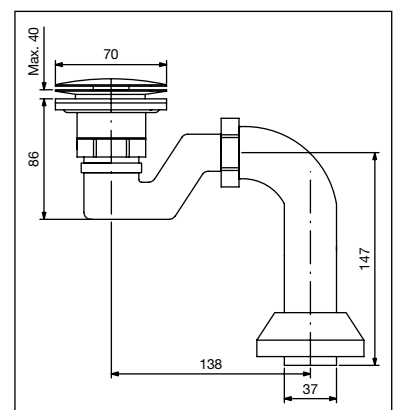



## MECCANISMO A CREMAGLIERA RACK DRIVE SYSTEM

### 6004

Scarico vasca con meccanismo  
a cremagliera

Bath pop-up waste  
with rack drive system

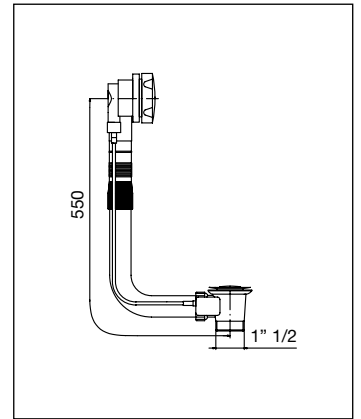

Meccanismo di comando a cremagliera  
con perno frontale estraibile.  
**Ideale per ristrutturazione, sostituzione  
o sovrapposizione della vasca**

Rack drive system  
with removable front pin.

**Ideal for restructuring, replacing  
or bathtub overlapping**



### 6004/1151

Scarico vasca con meccanismo  
a cremagliera, manopola minimalista  
e tappo Ø 70 mm

Bath pop-up waste with rack drive system,  
minimalist control knob  
and plug Ø 70 mm

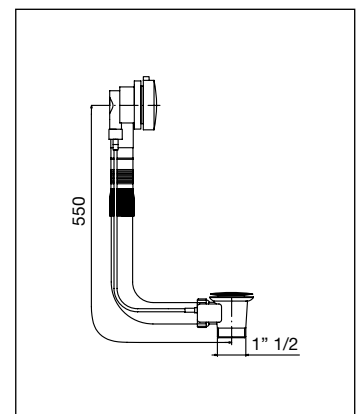

## SCARICHI IN POLIPROPILENE CON EROGAZIONE POLYPROPYLENE DRAINS WITH WATER FILLING

### 260

Scarico vasca in polipropilene con erogazione acqua dal troppo pieno e tubo corrugato flessibile

Bath pop-up waste in polypropylene with water filling system from overflow and corrugated flexible pipe



### 260/1151

Scarico vasca in polipropilene con erogazione acqua dal troppo pieno, tubo corrugato flessibile, manopola minimalista e tappo Ø 70 mm

Bath pop-up waste in polypropylene with water filling system from overflow, corrugated flexible pipe, minimalist control knob and plug Ø 70 mm

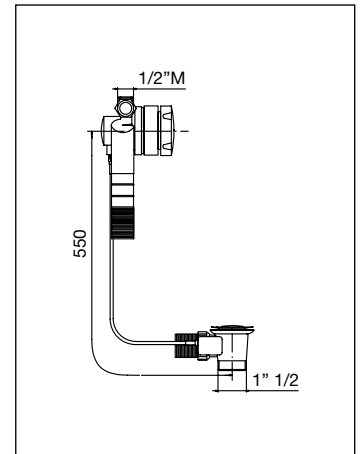

### 264/1151

Scarico vasca in polipropilene con erogazione acqua dal troppo pieno, tubo rigido, manopola minimalista e tappo Ø 70 mm

Bath pop-up waste in polypropylene with water filling system from overflow, rigid pipe, minimalist control knob and plug Ø 70 mm



### 264

Scarico vasca in polipropilene con erogazione acqua dal troppo pieno e tubo rigido

Bath pop-up waste in polypropylene with water filling system from overflow and rigid pipe

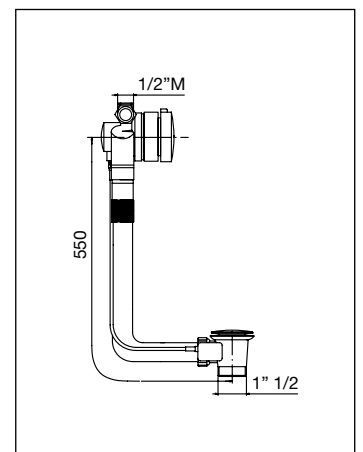

## SCARICHI IN POLIPROPILENE POLYPROPYLENE DRAINS

### 1001

Scarico vasca in polipropilene con tubo corrugato flessibile

Bath pop-up waste in polypropylene with corrugated flexible pipe

### 1001/1151

Scarico vasca in polipropilene con tubo corrugato flessibile, manopola minimalista e tappo Ø 70 mm

Bath pop-up waste in polypropylene with corrugated flexible pipe, minimalist control knob and plug Ø 70 mm

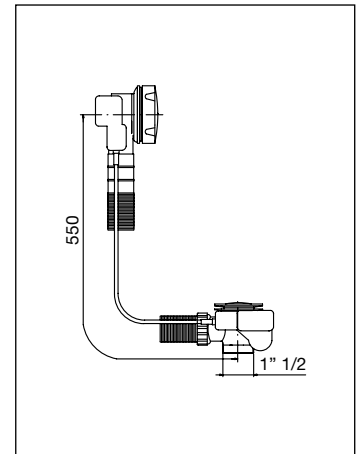

### 1004/1151

Scarico vasca in polipropilene con tubo rigido, manopola minimalista e tappo Ø 70 mm

Bath pop-up waste in polypropylene with rigid pipe, minimalist control knob and plug Ø 70 mm

### 1004

Scarico vasca in polipropilene con tubo rigido

Bath pop-up waste in polypropylene with rigid pipe

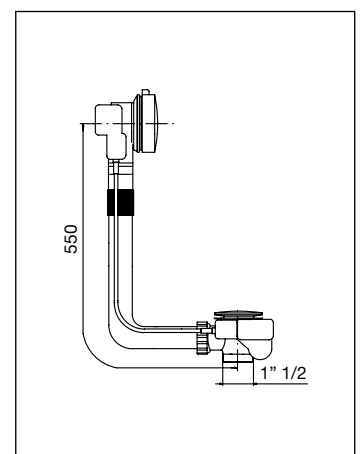

**TUBO RAME Ø 34 mm**  
**COPPER PIPE Ø 34 mm**

**101**

Scarico vasca Mod. LUSO con meccanismo eccentrico e scarico del troppo pieno maggiorato

Bath pop-up waste Mod. LUXURY with eccentric mechanism and increased overflow drain

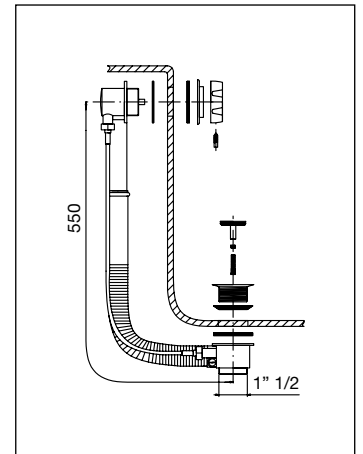

**201**

Scarico vasca Mod. LUSO con meccanismo eccentrico, scarico del troppo pieno maggiorato e erogazione dal troppo pieno

Bath pop-up waste Mod. LUXURY with eccentric mechanism, increased overflow drain and water filling system from overflow

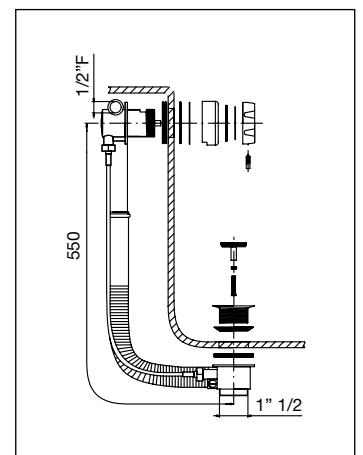

TUBO RAME Ø 30 mm  
COPPER PIPE Ø 30 mm

**300**

Scarico vasca Mod. SIMPLY  
con meccanismo semplice  
e piletta in ottone

Bath pop-up waste Mod. SIMPLY  
with simple mechanism  
and drain strainer in brass

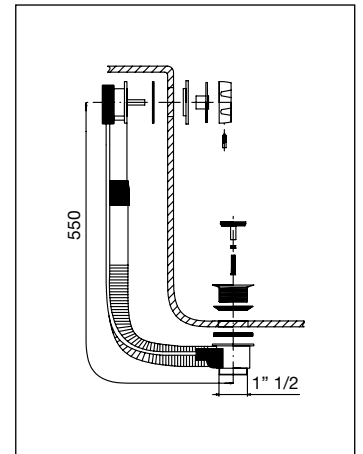

**400**

Scarico vasca Mod. STANDARD  
con meccanismo semplice  
e piletta in acciaio

Bath pop-up waste Mod. STANDARD  
with simple mechanism  
and drain strainer in stainless steel

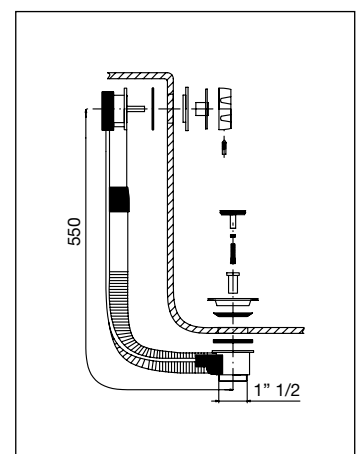



TUBO RAME Ø 30 mm  
COPPER PIPE Ø 30 mm

**600**

Scarico vasca Mod. EXPORT  
con meccanismo eccentrico  
e piletta in ottone

Bath pop-up waste Mod. EXPORT  
with eccentric mechanism  
and drain strainer in brass

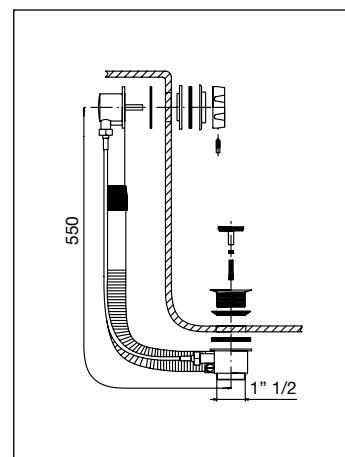

## OTTONE-PLASTICA BRASS-PLASTIC

### 250

Scarico vasca con corpo troppo pieno e leveraggi di comando in ottone, parte di scarico in polipropilene, tubo corrugato flessibile ed erogazione dal troppo pieno

Bath pop-up waste with overflow body and command leverages in brass, drain body in polypropylene, corrugated flexible pipe and water filling system from overflow

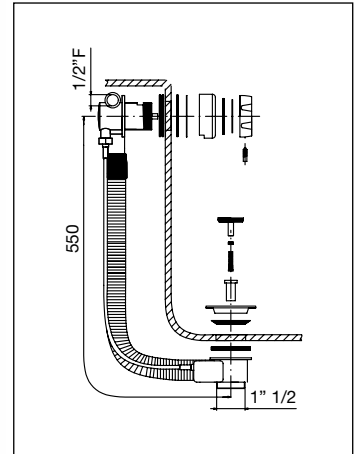

### 500

Scarico vasca con corpo troppo pieno e leveraggi di comando in ottone, parte di scarico in polipropilene e tubo corrugato flessibile

Bath pop-up waste with overflow body and command leverages in brass, drain body in polypropylene and corrugated flexible pipe

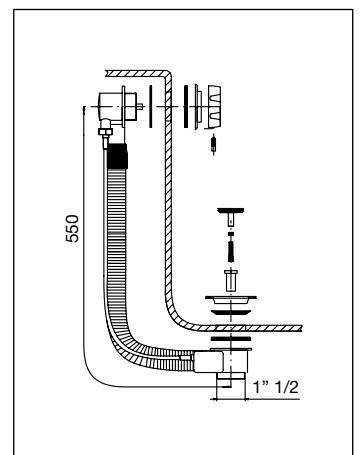

## CLICK-CLACK CLICK-CLACK

### 610

Scarico vasca in ottone  
con meccanismo CLICK-CLACK

Bath CLICK-CLACK waste in brass

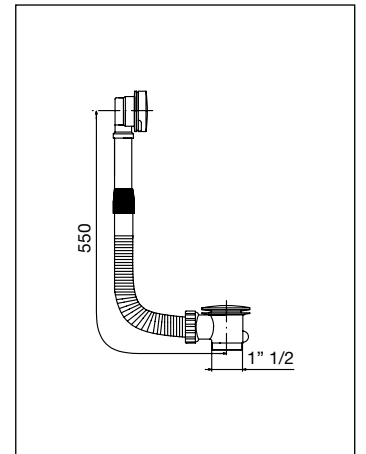

### 610/AF

Scarico vasca in ottone con meccanismo  
CLICK-CLACK e uscita frontale

Bath CLICK-CLACK waste in brass  
with frontal outlet connection

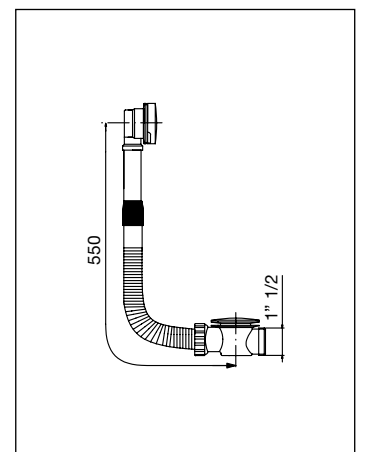
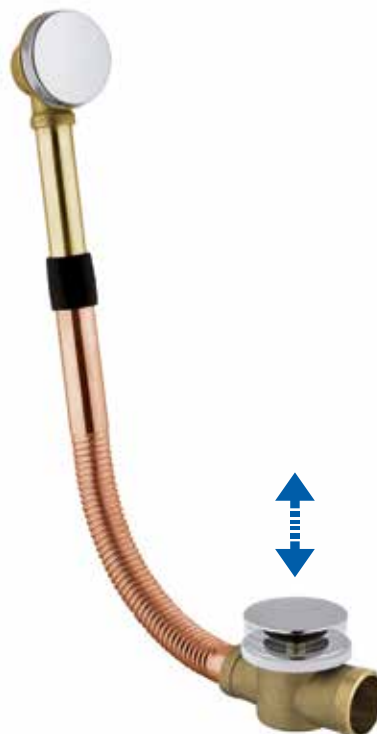

## CLICK-CLACK CLICK-CLACK

### 1011

Scarico vasca in polipropilene con meccanismo CLICK-CLACK e tubo corrugato flessibile

Bath CLICK-CLACK waste in polypropylene and corrugated flexible overflow pipe

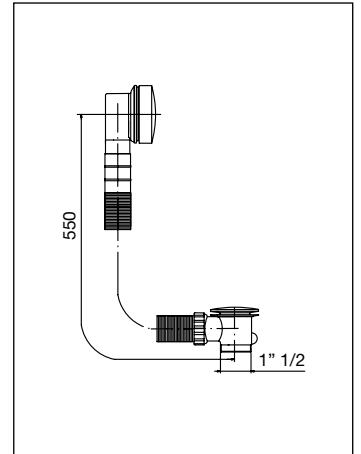

### 1011/AF

Scarico vasca in polipropilene con meccanismo CLICK-CLACK, uscita frontale e tubo corrugato flessibile

Bath CLICK-CLACK waste in polypropylene with frontal outlet connection and corrugated flexible overflow pipe

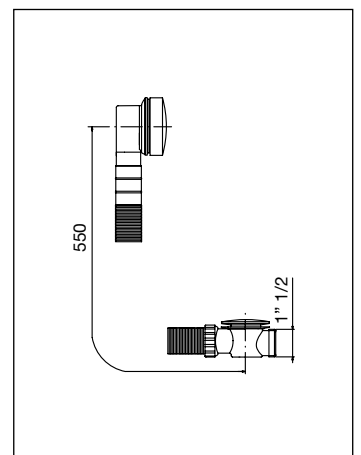

## CLICK-CLACK CLICK-CLACK

### 2611

Scarico vasca in polipropilene con meccanismo CLICK-CLACK, erogazione dal troppo pieno e tubo corrugato flessibile

Bath CLICK-CLACK waste in polypropylene, water filling system from overflow and corrugated flexible overflow pipe

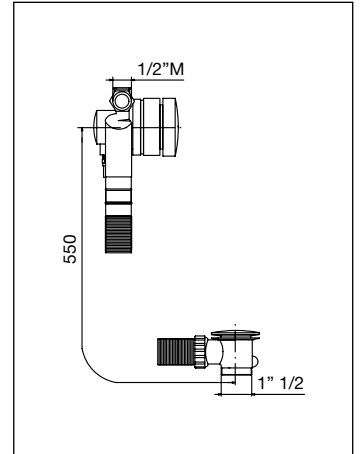

### 2611/AF

Scarico vasca in polipropilene con meccanismo CLICK-CLACK, erogazione dal troppo pieno, uscita frontale e tubo corrugato flessibile

Bath CLICK-CLACK waste in polypropylene with water filling system from overflow, frontal outlet connection and corrugated flexible overflow pipe

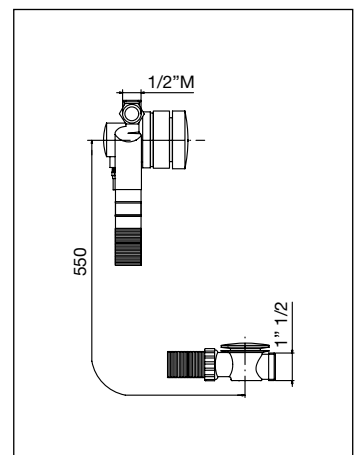

## CLICK-CLACK DESIGN DESIGN CLICK-CLACK

### 1011/Q

Scarico vasca in polipropilene con meccanismo CLICK-CLACK, design quadrato e tubo corrugato flessibile

Bath CLICK-CLACK waste in polypropylene, square design and corrugated flexible overflow pipe

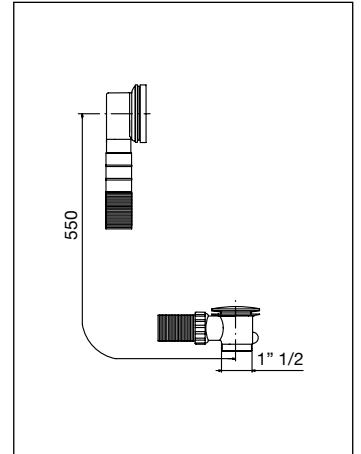

### 1012

Scarico vasca CLICK-CLACK universale per vasche senza troppo pieno o con troppo pieno integrato

Universal CLICK-CLACK drain, for bathtub without overflow or with integrated overflow

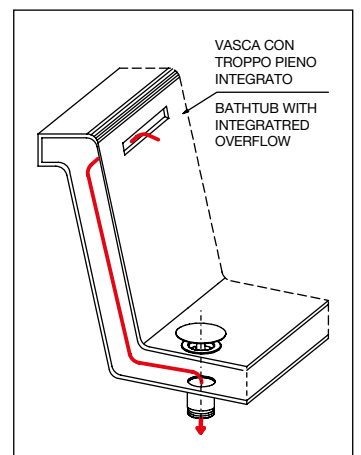
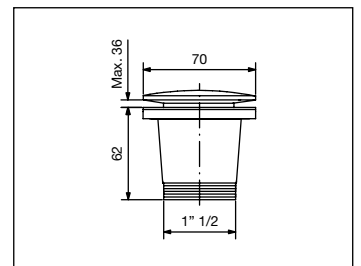

### 1012/AL

Scarico vasca CLICK-CLACK universale per vasche senza troppo pieno o con troppo pieno integrato

Universal CLICK-CLACK drain, for bathtub without overflow or with integrated overflow

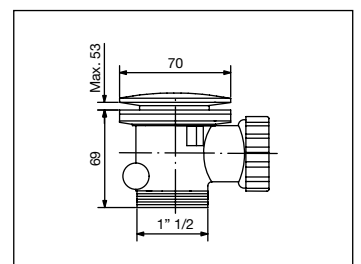

## VALVOLA DI DRENAGGIO DRAIN VALVE

### 602

Scarico in ottone per vasca idromassaggio con meccanismo eccentrico e valvola di drenaggio in ottone

Brass bath pop-up waste for hydromassage bathtub with eccentric mechanism and brass drain valve

### 202

Scarico in ottone per vasca idromassaggio con meccanismo eccentrico, erogazione dal troppo pieno e valvola di drenaggio in ottone

Brass bath pop-up waste for hydromassage bathtub with eccentric mechanism, water filling system from overflow and brass drain valve

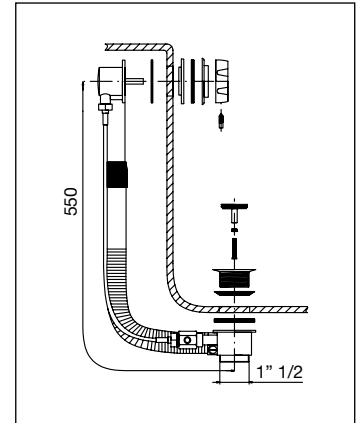

### 652

Scarico in ottone per vasca idromassaggio con meccanismo eccentrico, valvola di drenaggio in ottone e tubo corrugato flessibile

Brass bath pop-up waste for hydromassage bathtub with eccentric mechanism, brass drain valve and corrugated flexible overflow pipe

### 252

Scarico in ottone per vasca idromassaggio con meccanismo eccentrico, erogazione dal troppo pieno, valvola di drenaggio in ottone e tubo corrugato flessibile

Brass bath pop-up waste for hydromassage bathtub with eccentric mechanism, water filling system from overflow, brass drain valve and corrugated flexible overflow pipe



**Valvola di drenaggio in ottone**  
**Brass drain valve**  
**Brevettata - Patented**

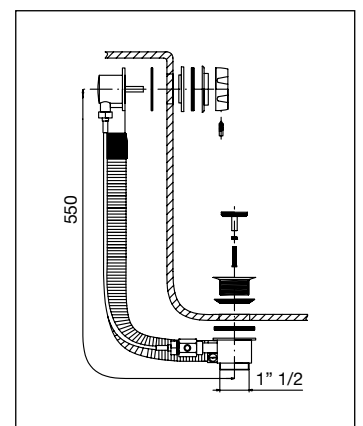

# KIT ASPIRAZIONE SUCTION KIT

**1500**

Scarico per vasca idromassaggio con KIT  
di aspirazione acqua

Bath pop-up waste for hydromassage bathtub  
with water suction KIT

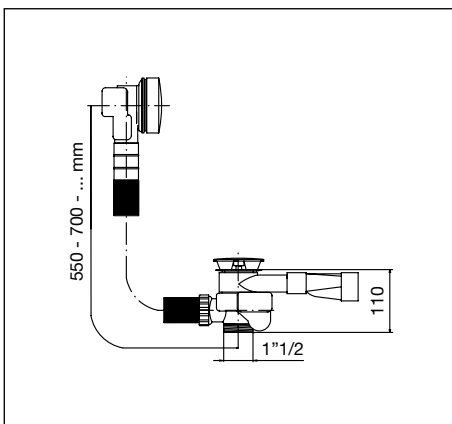

**Raccordo in PVC  
PVC connection**

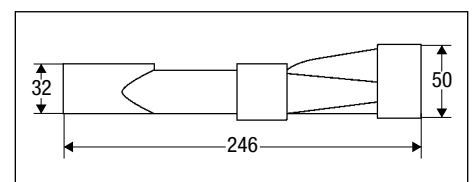



LUNGHEZZA CM – LENGTH CM									
	45	55	65	70	80	90	100	110	120
1200		●							
1200/L		●							
1210		●							
1210/L		●							
260		●		●	●	●	●	●	●
264		●		●					
1001	●	●		●	●	●	●	●	●
1004		●		●					
1011	●	●	●	●	●	●	●	●	●
2611		●	●	●	●	●	●	●	●
6004		●							
101		●	●	●	●	●	●		
201		●	●	●	●	●	●		
300		●							
400		●	●						
600		●	●	●	●	●	●		
610		●	●	●	●	●	●		
602		●		●	●	●			
202		●		●	●	●			
652		●		●	●	●			
252		●		●	●	●			
1500		●		●	●	●	●	●	●
250		●		●	●	●	●	●	●
500		●		●	●	●	●	●	●

Retrò  
Retro

Polipropilene  
Polypropylene

Ottone  
Brass

Valvola di drenaggio  
Drain valve

Idromassaggio con aspirazione  
Hydromassage with suction

Ottone-Plastica  
Brass-Plastic

La lunghezza della colonna vasca è calcolata dal centro della manopola al centro del tappo  
The length of bath pop-up waste is calculated from centre of command knob to centre of plug

Tutte le colonne vasca sono disponibili in tutte le lunghezze e finiture  
All bath pop-up waste are available in different sizes and in all finishings

**Cm 45** Colonna scarico per piatto doccia alto  
Pop-up waste for high shower tray

**Cm 55** Colonna scarico per vasca standard  
Pop-up waste for standard bathtub

**Cm 65** Colonna scarico per vasca a sedile  
Pop-up waste for sit down bathtub

**Cm 70-120** Colonna scarico per vasca speciale  
Pop-up waste for special bathtub

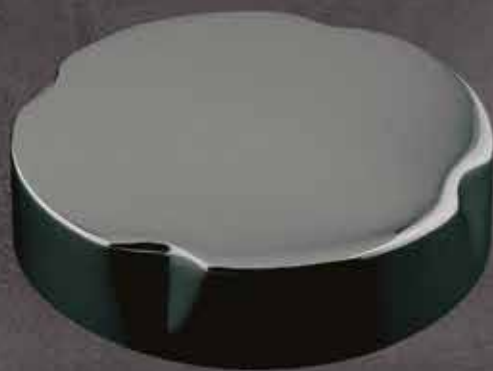

**RICAMBI**  
Spare parts

## RICAMBI PER VASCA SPARE PARTS FOR BATHTUB

**050**

Tappo standard completo in ottone Ø 43 mm

Complete standard brass plug Ø 43 mm

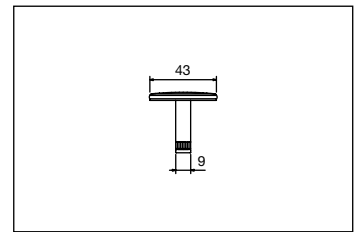

**051**

Tappo grande completo in ottone Ø 70 mm

Complete big brass plug Ø 70 mm

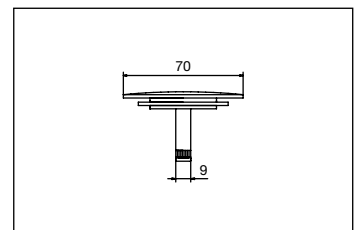

**049**

Tappo in gomma con copertura e catenella

Rubber plug with cover and chain

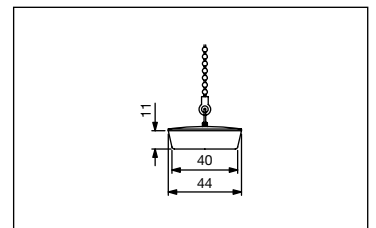

**051/CC**

Tappo in ottone Ø 70 mm con meccanismo  
CLICK-CLACK per vasca

Brass plug Ø 70 mm with CLICK-CLACK  
mechanism for bathtub

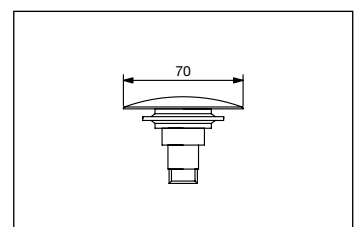

## RICAMBI PER VASCA SPARE PARTS FOR BATHTUB

**010**

Manopola con otto gole  
Eight grooves command knob

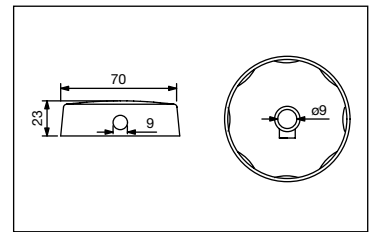

**011**

Manopola minimalista moderna  
Modern minimalist command knob

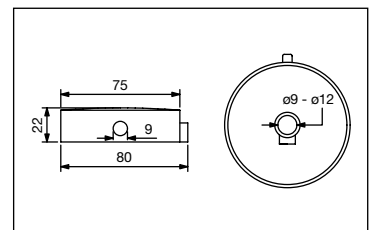

**012**

Manopola standard  
Standard command knob

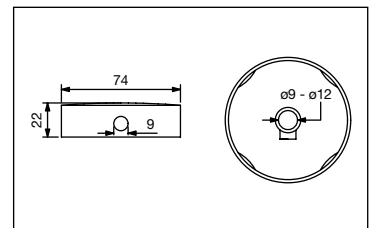

**029**

Guarnizione doppia a labbro  
Double lip seal

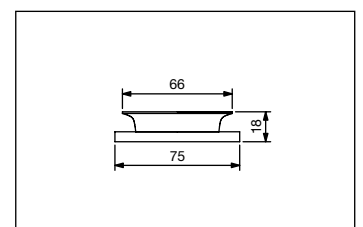

## RICAMBI PER VASCA SPARE PARTS FOR BATHTUB

### 062

Piletta in ottone con vite di fissaggio  
e guarnizione conica  
per scarichi a vista

Brass waste flange with fixing screw  
and conical gasket  
for exposed bathtub drains

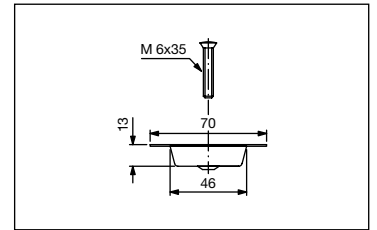

### 060

Piletta in ottone con guarnizione conica  
per serie 100-200-600

Brass waste flange with conical gasket  
for serie 100-200-600

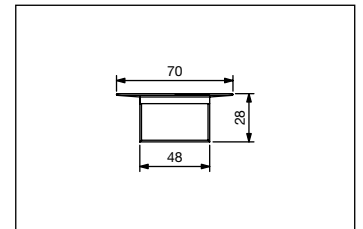

### 061

Piletta in acciaio con guarnizione conica  
per serie 250-260-400-500-1001

Stainless steel waste flange with conical  
gasket for serie 250-260-400-500-1001

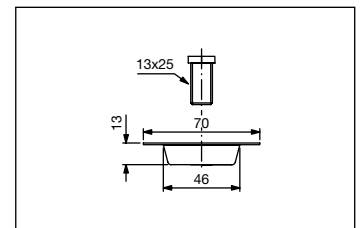

### 041

Bocca erogazione in ottone  
per scarichi serie 201 e 250

Brass filler spout for drains  
serie 201 and 250

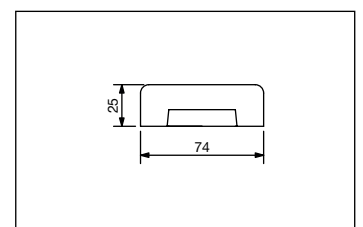

## RICAMBI PER VASCA SPARE PARTS FOR BATHTUB

**09**

Copertura in ABS per troppo pieno

ABS overflow cover

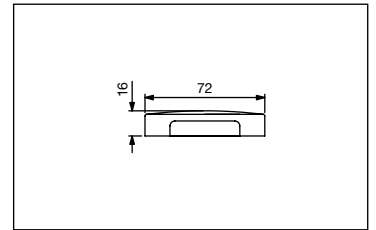

**07/Q**

Copertura in ottone per troppo pieno

Brass overflow cover

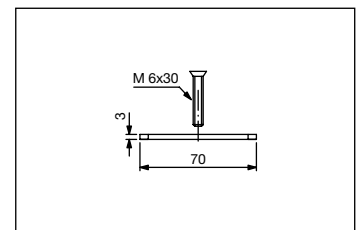

**048**

Griglia in ottone a sei fori per troppo pieno  
con vite di fissaggio

Brass overflow cover six holes  
with fixing screw

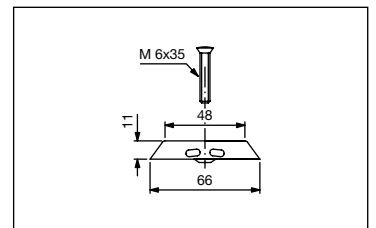

**08**

Bocca erogazione in ABS  
per scarichi serie 260 e 2611

ABS filler spout for drains  
serie 260 and 2611

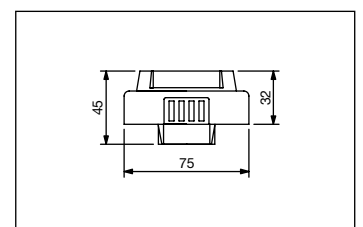





# SIFONI E CODOLI

Traps and tail connections



## SIFONI TRAPS

### 800

Sifone pesante da 1" 1/2 in ottone con raccordo dritto in ottone Ø 40 mm

Heavy brass trap 1" 1/2 with brass straight connection Ø 40 mm

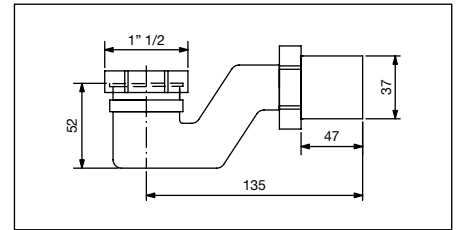

### 803

Sifone pesante da 1" 1/2 in ottone con raccordo dritto in ABS Ø 40 mm

Heavy brass trap 1" 1/2 with ABS straight connection Ø 40 mm

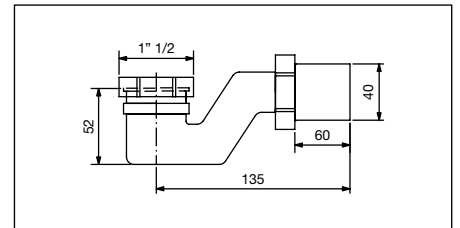

### 805/CO

Sifone ribassato e orientabile da 1" 1/2 in plastica con dado in ottone e uscita Ø 40-50 mm

Low plastic and orientable 1" 1/2 trap with brass nut and outlet Ø 40-50 mm

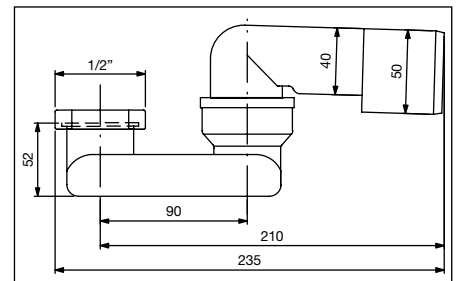

### 806/CO

Sifone ribassato e orientabile da 1" 1/2 in plastica, con dado in ottone e uscita da 1" 1/2

Low plastic and orientable 1" 1/2 trap with brass nut and outlet 1" 1/2

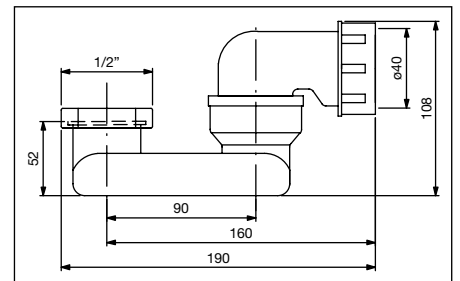

### 805

Sifone ribassato e orientabile da 1" 1/2 in plastica e uscita Ø 40-50 mm

Low plastic and orientable 1" 1/2 trap with outlet Ø 40-50 mm

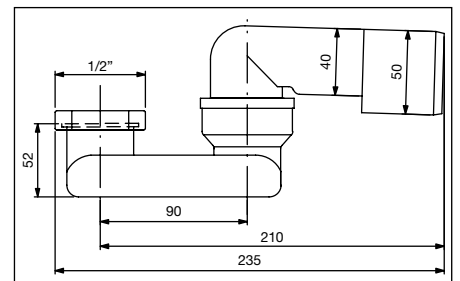

### 806

Sifone ribassato e orientabile da 1" 1/2 in plastica e uscita da 1" 1/2

Low plastic and orientable 1" 1/2 trap with outlet 1" 1/2

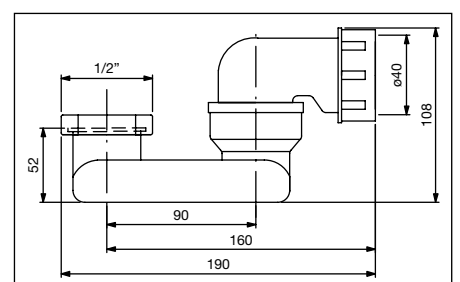

## SIFONI E CODOLI TRAPS AND TAIL CONNECTIONS

### 801

Sifone in tubo di ottone da 1" 1/2  
con uscita Ø 37 mm

Brass P-Trap 1" 1/2 with outlet Ø 37 mm

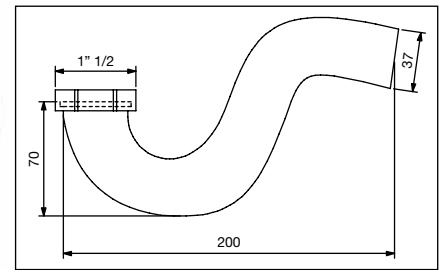

### 021

Codolo curvo in tubo di ottone Ø 37 mm  
con dado 1" 1/2

Brass curved tail connection Ø 37 mm  
with 1" 1/2 nut

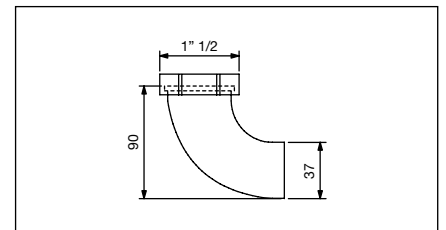

### 022

Codolo curvo in PVC Ø 40 mm  
con dado 1" 1/2

PVC curved tail connection Ø 40 mm  
with 1" 1/2 nut

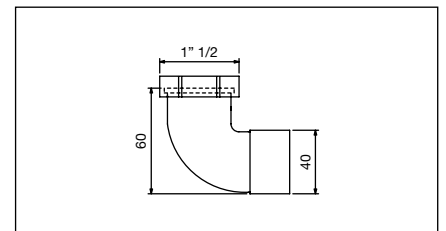

### 025

Codolo dritto in tubo di ottone Ø 40 mm  
con dado 1" 1/2

Brass straight tail connection Ø 40 mm  
with 1" 1/2 nut

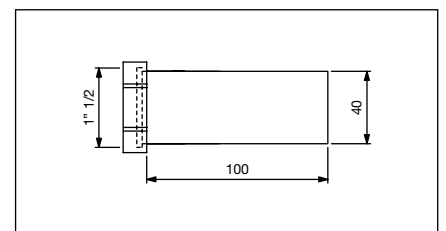

### 026

Codolo dritto in ABS Ø 40 mm  
con dado 1" 1/2

ABS straight tail connection Ø 40 mm  
with 1" 1/2 nut

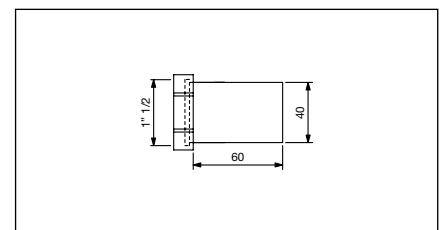



# SCARICHI LAVABO

Washbasin drains

## SCARICHI LAVABO WASHBASIN DRAINS

### 522/ACPL

Scarico universale 1"1/4 CLICK-CLACK  
con raccordo in plastica

Universal CLICK-CLACK drain 1"1/4  
with plastic connection

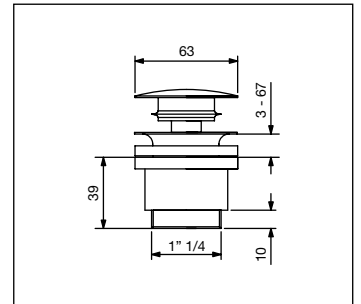

### 522/L

Scarico universale 1"1/4 CLICK-CLACK  
con meccanismo in ottone

Universal CLICK-CLACK drain 1"1/4  
with brass mechanism

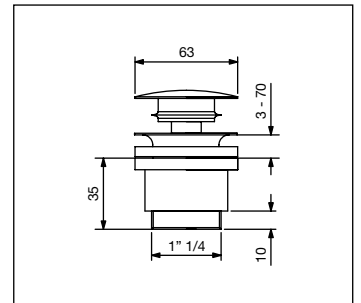

### 522/AC.10

Scarico universale 1"1/4 CLICK-CLACK  
in acciaio AISI 316 lucido

Universal CLICK-CLACK drain 1"1/4  
in shiny stainless steel AISI 316

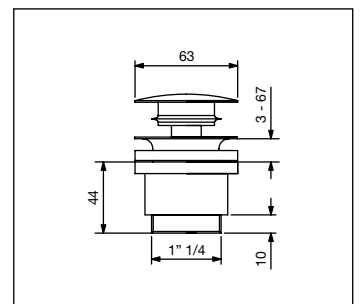

### 522/AC.11

Scarico universale 1"1/4 CLICK-CLACK  
in acciaio AISI 316 spazzolato

Universal CLICK-CLACK drain 1"1/4  
in brushed stainless steel AISI 316

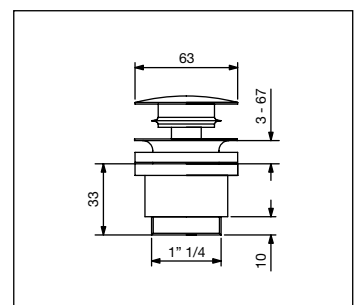

## SCARICHI LAVABO - TAPPO TONDO WASHBASIN DRAINS - ROUND COVER

### 521

Scarico 1" 1/4 CLICK-CLACK  
senza troppo pieno

CLICK-CLACK drain 1" 1/4  
without overflow

### 521/SA

Versione SEMPRE APERTO

ALWAYS OPEN version

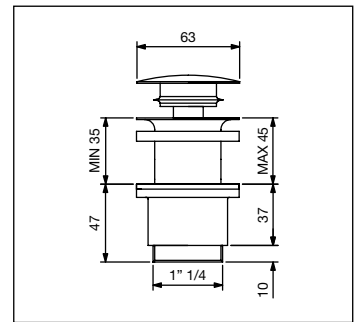

### 521/TP

Scarico 1" 1/4 CLICK-CLACK  
con troppo pieno

CLICK-CLACK drain 1" 1/4  
with overflow

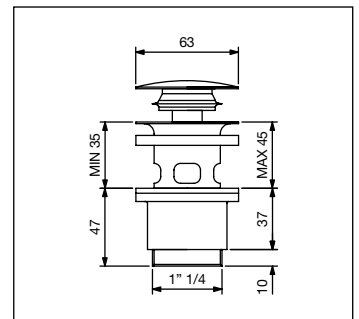

### 522

Scarico universale 1" 1/4 CLICK-CLACK

Universal CLICK-CLACK drain 1" 1/4

### 522/SA

Versione SEMPRE APERTO

ALWAYS OPEN version

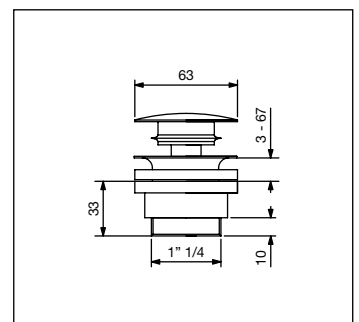

### 523

Scarico 1" 1/4 CLICK-CLACK  
con filettatura H 100 mm

CLICK-CLACK drain 1" 1/4  
with thread H 100 mm

### 523/SA

Versione SEMPRE APERTO

ALWAYS OPEN version

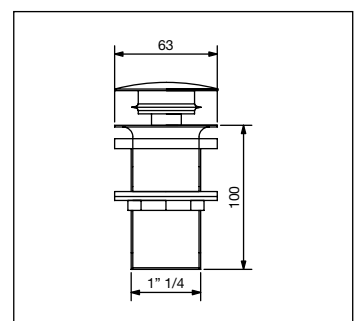

## SCARICHI LAVABO - TAPPO CERAMICA WASHBASIN DRAINS - CERAMIC COVER

### 521/CER

Scarico 1" 1/4 CLICK-CLACK  
senza troppo pieno

CLICK-CLACK drain 1" 1/4  
without overflow

### 521/CERSA

Versione SEMPRE APERTO

ALWAYS OPEN version

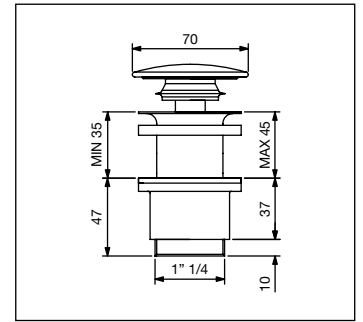

### 521/TPCER

Scarico 1" 1/4 CLICK-CLACK  
con troppo pieno

CLICK-CLACK drain 1" 1/4  
with overflow

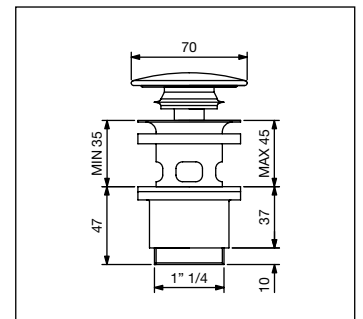

### 522/CER

Scarico universale 1" 1/4 CLICK-CLACK

Universal CLICK-CLACK drain 1" 1/4

### 522/CERSA

Versione SEMPRE APERTO

ALWAYS OPEN version

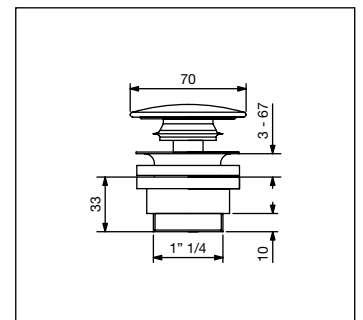

### 523/CER

Scarico 1" 1/4 CLICK-CLACK  
con filettatura H 100 mm

CLICK-CLACK drain 1" 1/4  
with thread H 100 mm

### 523/CERSA

Versione SEMPRE APERTO

ALWAYS OPEN version

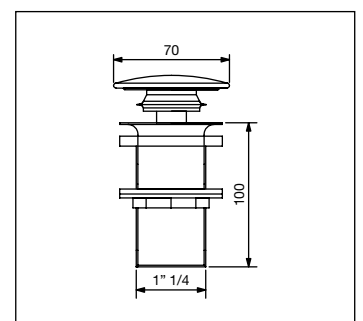

## SCARICHI LAVABO - TAPPO QUADRATO WASHBASIN DRAINS - SQUARE COVER

### 521/Q

Scarico 1" 1/4 CLICK-CLACK  
senza troppo pieno

CLICK-CLACK drain 1" 1/4  
without overflow

### 521/QSA

Versione SEMPRE APERTO

ALWAYS OPEN version

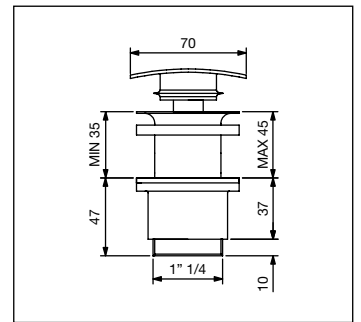

### 521/TPQ

Scarico 1" 1/4 CLICK-CLACK  
con troppo pieno

CLICK-CLACK drain 1" 1/4  
with overflow

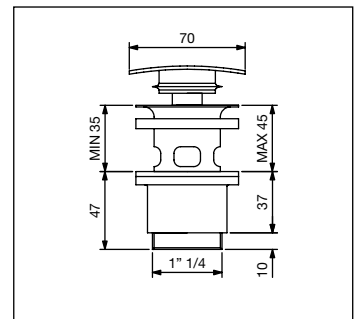

### 522/Q

Scarico universale 1" 1/4 CLICK-CLACK

Universal CLICK-CLACK drain 1" 1/4

### 522/QSA

Versione SEMPRE APERTO

ALWAYS OPEN version

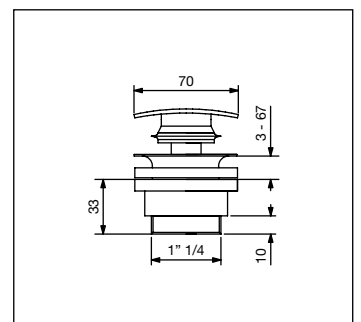

### 523/Q

Scarico 1" 1/4 CLICK-CLACK  
con filettatura H 100 mm

CLICK-CLACK drain 1" 1/4  
with thread H 100 mm

### 523/QSA

Versione SEMPRE APERTO

ALWAYS OPEN version

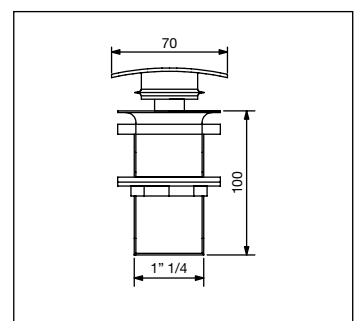

## RICAMBI PER LAVABO SPARE PARTS FOR WASHBASIN

### 050/CC

Tappo tondo in ottone per lavabo  
con meccanismo CLICK-CLACK

Round brass cover for washbasin  
with CLICK-CLACK mechanism

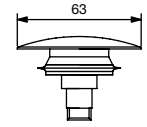

### 050/CER

Tappo tondo in ceramica per lavabo  
con meccanismo CLICK-CLACK

Round ceramic cover for washbasin  
with CLICK-CLACK mechanism

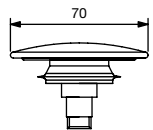

### 050/Q

Tappo quadrato in ottone per lavabo  
con meccanismo CLICK-CLACK

Square brass cover for washbasin  
with CLICK-CLACK mechanism

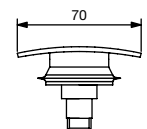



## SCARICHI LAVABO WASHBASIN DRAINS

### 510

Scarico in ottone 1" per lavabo e bidet con tappo standard in ottone con cestello

1" Brass pop-up waste for washbasin and bidet with standard brass plug with strainer

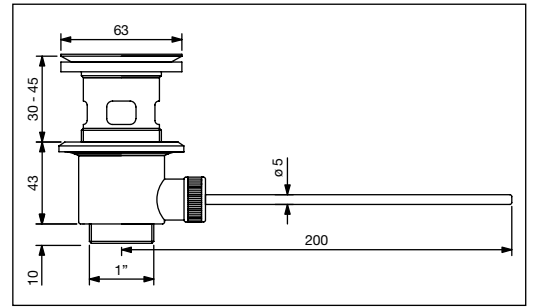

### 510/SOT

Scarico in ottone sabbiato 1" per lavabo e bidet con tappo standard in ottone con cestello

1" Sandblasted brass pop-up waste for washbasin and bidet with standard brass plug with strainer

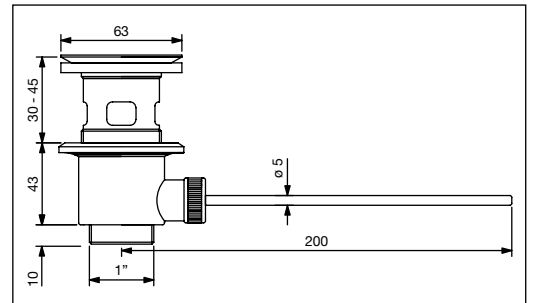

### 520

Scarico in ottone 1" 1/4 per lavabo e bidet con tappo standard in ottone con cestello

1" 1/4 Brass pop-up waste for washbasin and bidet with standard brass plug with strainer

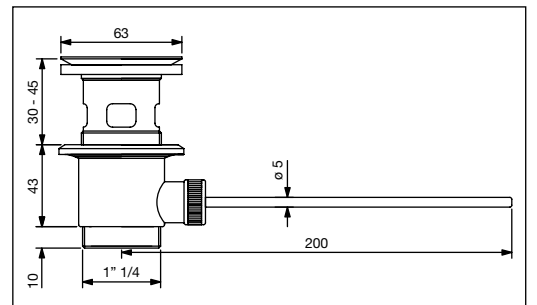

### 520/SOT

Scarico in ottone sabbiato 1" 1/4 per lavabo e bidet con tappo standard in ottone con cestello

1" 1/4 Sandblasted brass pop-up waste for washbasin and bidet with standard brass plug with strainer

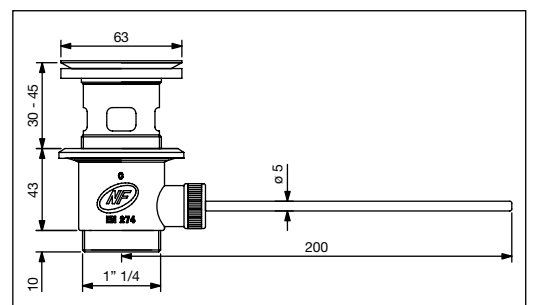

## SCARICHI LAVABO WASHBASIN DRAINS

### 510/52

Scarico in ottone 1" per lavabo e bidet con tappo SYNCRO antivandalo in ottone

1" Brass pop-up waste for washbasin and bidet with SYNCRO antitheft brass plug

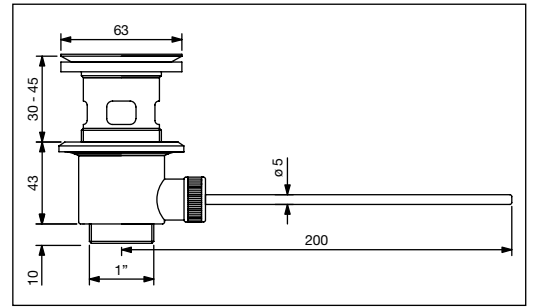

### 510/52SOT

Scarico in ottone sabbiato 1" per lavabo e bidet con tappo SYNCRO antivandalo in ottone

1" Sandblasted brass pop-up waste for washbasin and bidet with SYNCRO antitheft brass plug

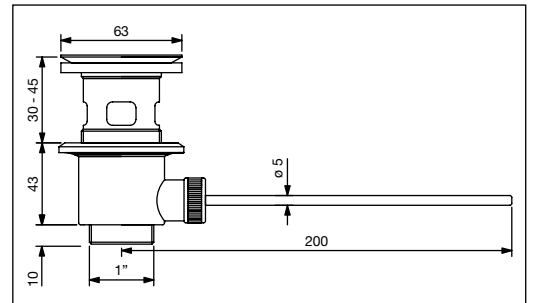

### 520/52

Scarico in ottone 1" 1/4 per lavabo e bidet con tappo SYNCRO antivandalo in ottone

1" 1/4 Brass pop-up waste for washbasin and bidet with SYNCRO antitheft brass plug

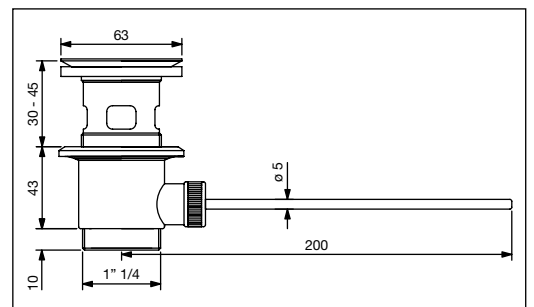

### 520/52SOT

Scarico in ottone sabbiato 1" 1/4 per lavabo e bidet con tappo SYNCRO antivandalo in ottone

1" 1/4 Sandblasted brass pop-up waste for washbasin and bidet with SYNCRO antitheft brass plug

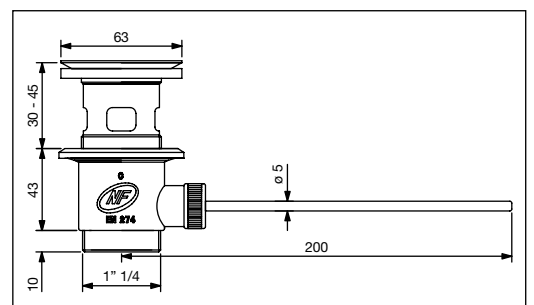

## SCARICHI LAVABO WASHBASIN DRAINS

### 520/PL

Scarico in plastica 1"1/4 per lavabo e bidet con tappo standard in acciaio con cestello

1"1/4 Plastic pop-up waste for washbasin and bidet with standard stainless steel plug with strainer

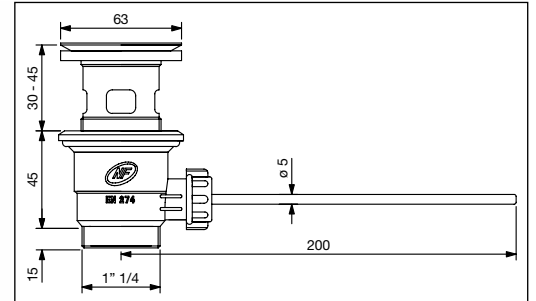

### 520/HO

Scarico in Hostaform 1"1/4 per lavabo e bidet con piletta e tappo standard in acciaio con cestello

1"1/4 Hostaform pop-up waste for washbasin and bidet with standard stainless steel plug with strainer

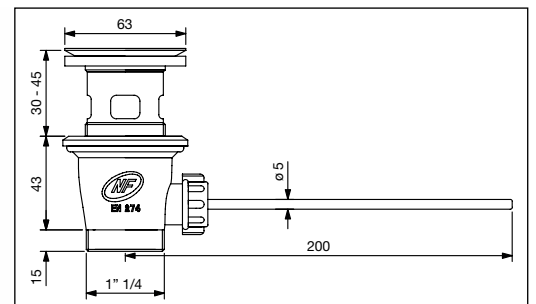

### 520/ZA

Scarico in Zama 1"1/4 per lavabo e bidet con tappo standard in ottone con cestello

1"1/4 Zamak pop-up waste for washbasin and bidet with standard brass plug with strainer

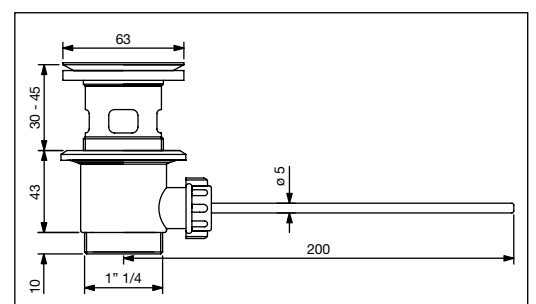

## SCARICHI LAVABO - RICAMBI WASHBASIN DRAINS - SPARE PARTS

### 055

Tappo standard in ottone con cestello  
1"1/4 per scarico lavabo e bidet

Standard brass plug with strainer  
1"1/4 for washbasin and bidet waste

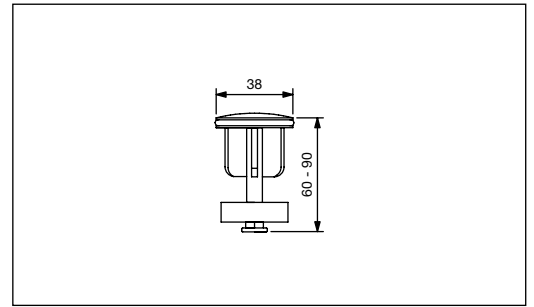

### 052

Tappo SYNCRO antivandalo in ottone  
1"1/4 per scarico lavabo e bidet

SYNCRO antitheft brass plug  
1"1/4 for washbasin and bidet waste

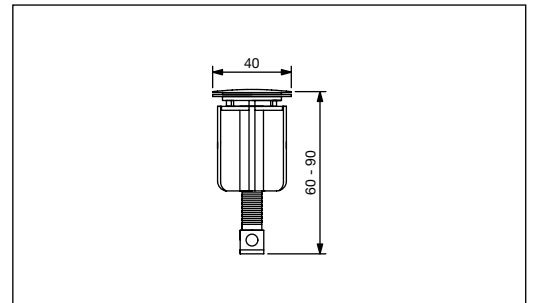

### 053

Tappo SYNCRO antivandalo Ø 63 mm  
in ottone per scarico lavabo e bidet

SYNCRO antitheft brass plug Ø 63 mm  
for washbasin and bidet waste

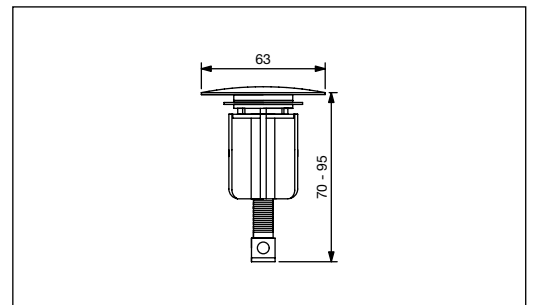

### 053/CER

Tappo SYNCRO antivandalo Ø 70 mm  
in ceramica per scarico lavabo e bidet

SYNCRO antitheft ceramic plug Ø 70 mm  
for washbasin and bidet waste

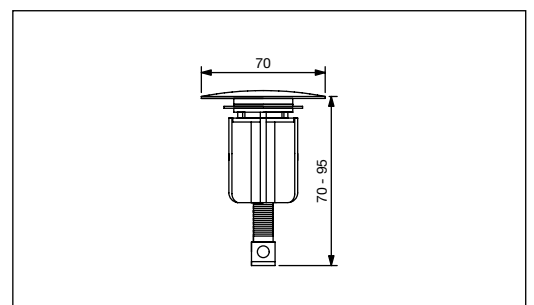

## SCARICHI LAVABO - RICAMBI WASHBASIN DRAINS - SPARE PARTS

### 054

KIT conversione da piletta pop-up 1"1/4  
a tappo CLICK-CLACK Ø 63 mm  
per lavabo e bidet

Conversion KIT from 1"1/4 pop-up drain  
to CLICK-CLACK plug Ø 63 mm  
for washbasin and bidet

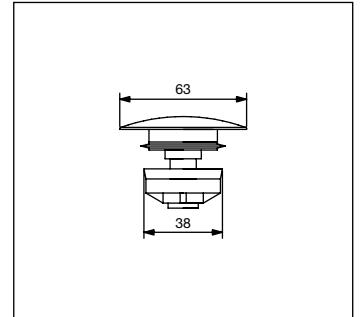

### TPL50

Tappo copriforo in ottone Ø 49 mm

Brass hole cover Ø 49 mm

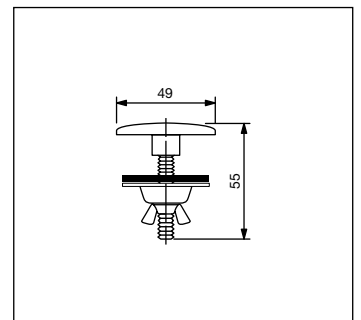

### DIS114

Distanziale in ABS per scarichi lavabo

ABS spacer for washbasin drains

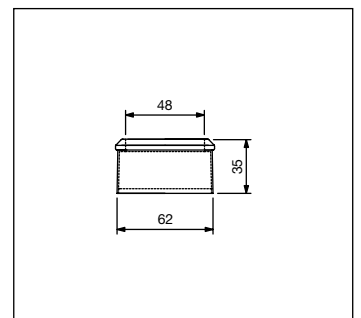



# SIFONI LAVABO

Washbasin traps

## SIFONI SALVASPAZIO 1" 1/4 1" 1/4 SAVESPACE TRAPS

### 890/K

Sifone salvaspazio 1" 1/4  
tondo universale

Universal 1" 1/4 savespace  
round trap

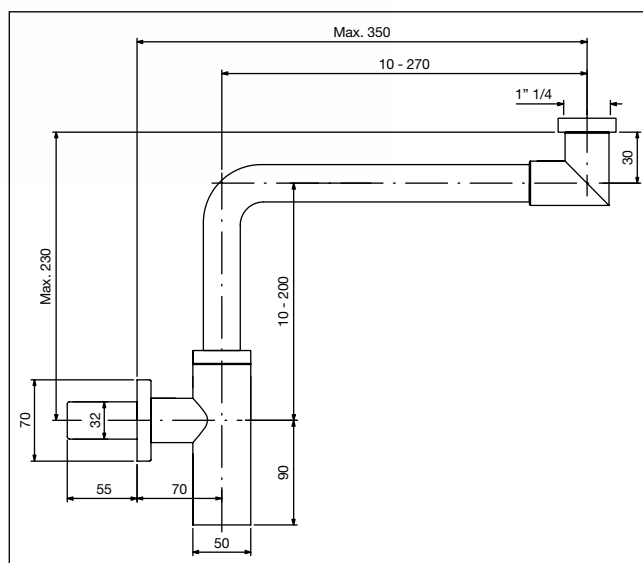

### 890/LM

Sifone minimale ribassato salvaspazio  
1" 1/4 con ispezione

Low minimal 1" 1/4 savespace trap  
with inspection

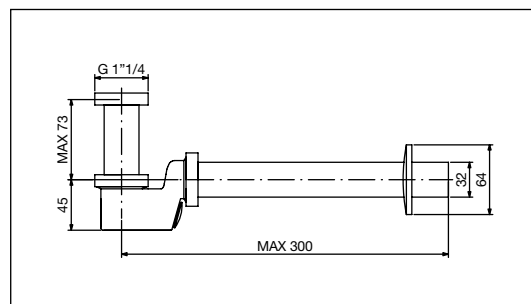

## SIFONI DESIGN 1" 1/4 1" 1/4 DESIGN TRAPS

### 890/T

Sifone design tondo 1" 1/4  
in ottone

1" 1/4 Round design trap  
in brass

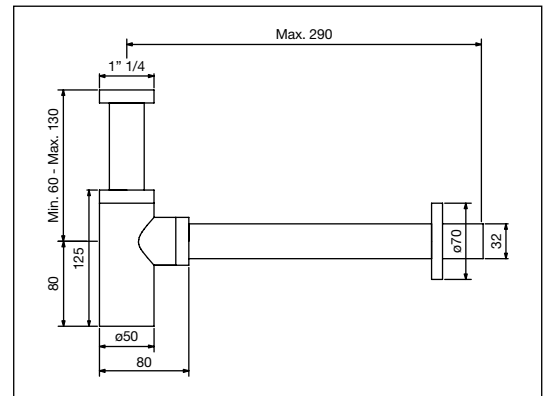

### 890/TC

Sifone design tondo ribassato 1" 1/4  
in ottone

1" 1/4 Low round design trap  
in brass

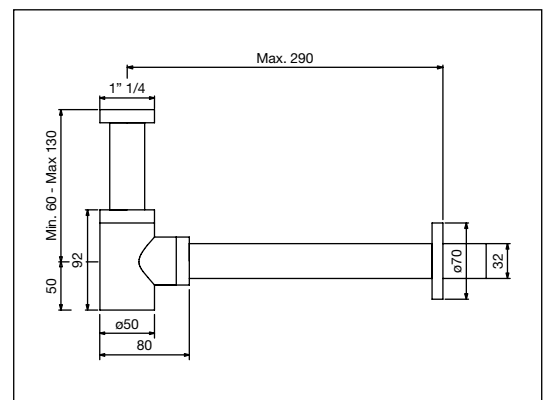

### 890/Q

Sifone design quadrato 1" 1/4  
in ottone

1" 1/4 Square design trap  
in brass

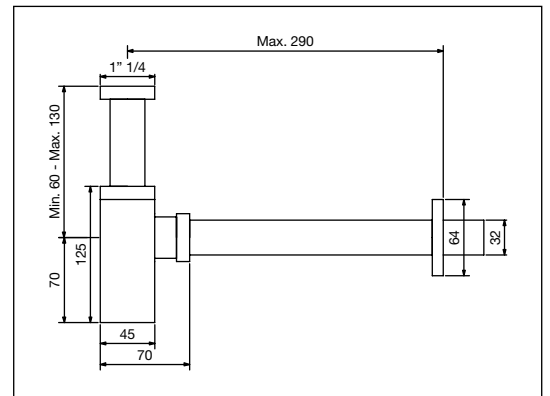

### 890/QC

Sifone design quadrato ribassato 1" 1/4  
in ottone

1" 1/4 Low square design trap  
in brass

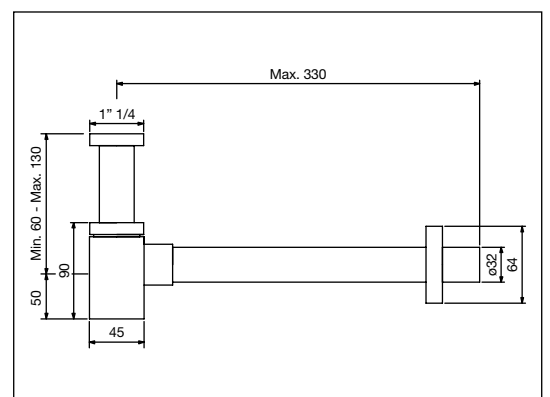



## SIFONI 1" 1/4 1" 1/4 TRAPS

### 890/P

Sifone a "P" 1" 1/4 in ottone

Brass P-Trap 1" 1/4

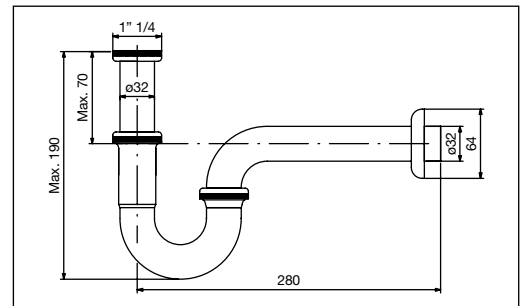

### 890/LOT

Sifone ispezionabile per lavabo  
a colonna 1" 1/4 in ottone

1" 1/4 Brass trap with inspection  
for column washbasin

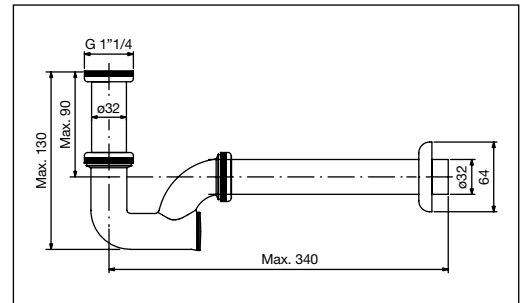

### 890/OF

Sifone 1" 1/4 in tubo flessibile  
in ottone con dado e rosone

1" 1/4 Siphon in brass flexible pipe  
with nut and rosette

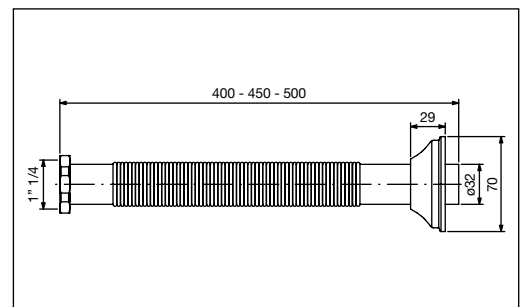

### 880

Sifone ispezionabile 1" 1/4  
Mod. LUSO in ottone

1" 1/4 Brass trap with inspection  
Mod. LUXURY

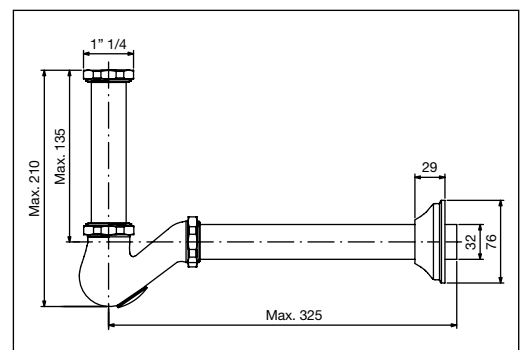

## SIFONI 1" 1/4 1" 1/4 TRAPS

### 890/B

Sifone a BOTTIGLIA 1" 1/4 in zama

1" 1/4 BOTTLE trap in zamak

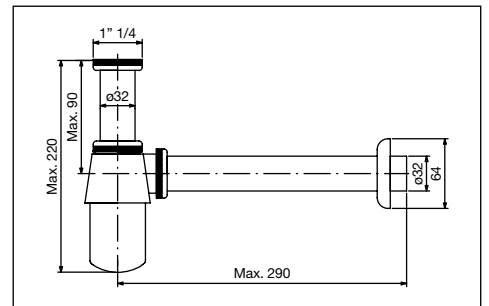

### 890/BOT

Sifone a BOTTIGLIA 1" 1/4 in ottone

1" 1/4 BOTTLE trap in brass

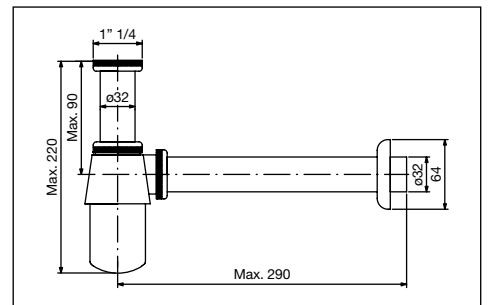

### 890/S

Sifone a ESSE 1" 1/4 in zama

1" 1/4 S-Trap in zamak

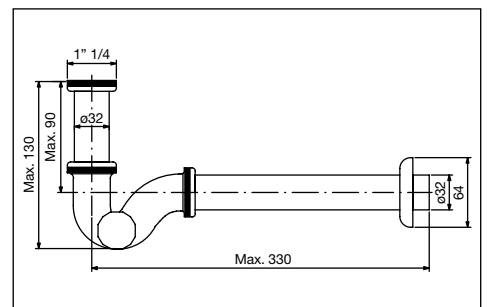

### 890/SOT

Sifone a ESSE 1" 1/4 in ottone

1" 1/4 S-Trap in brass

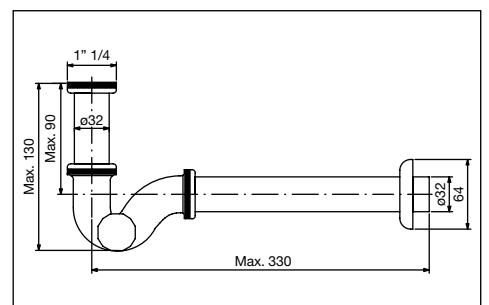

## ACCESSORI ACCESSORIES

### ES12

Tubo regolabile in ottone  
Ø 32 mm x 120 mm con O-Ring

Brass adjustable extension pipe  
Ø 32 mm x 120 mm with O-Ring

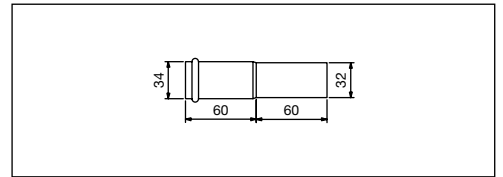

### ES25

Tubo regolabile in ottone  
Ø 32 mm x 250 mm con doppio O-Ring

Brass adjustable extension pipe  
Ø 32 mm x 250 mm with double O-Ring

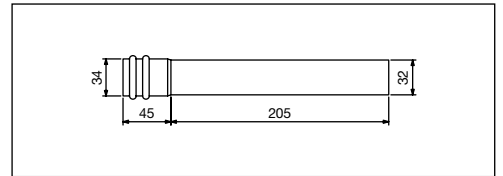

### 086

Tubo dritto in ottone Ø 32 mm

Straight brass pipe Ø 32 mm

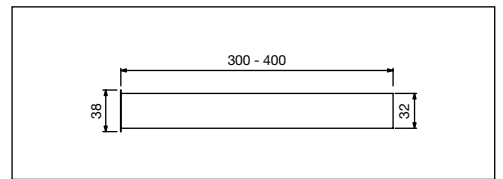

### 081

Tubo dritto in ottone Ø 32 mm

Straight brass pipe Ø 32 mm

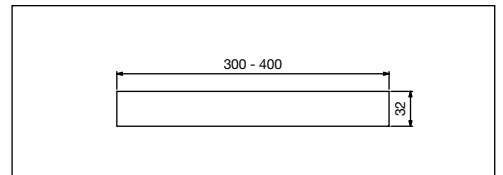

### 083

Rosetta in ottone  
per sifone lavabo 1" 1/4

1" 1/4 Brass rosette  
for washbasin trap

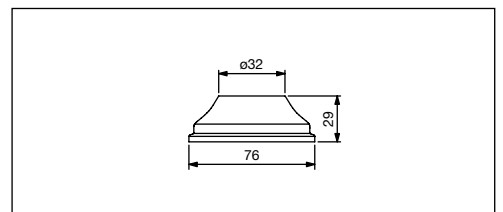



# RUBINETTI SOTTOLAVABO

Angle valves

## RUBINETTI SOTTOLAVABO DI DESIGN DESIGN ANGLE VALVES

### V1238

Rubinetto arresto MINIMALISTA tondo  
1/2" M x 3/8" M con filtro-stop e rosetta

MINIMALIST round angle valve  
1/2" M x 3/8" M with stop-filter and rosette

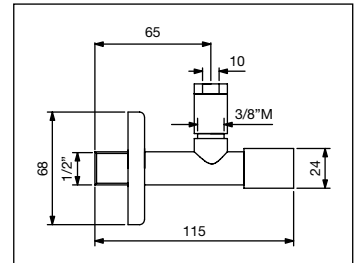

### V1212

Rubinetto arresto MINIMALISTA tondo  
1/2" M x 1/2" M con filtro-stop, snodo e rosetta

MINIMALIST round angle valve  
1/2" M x 1/2" M with stop-filter, joint and rosette

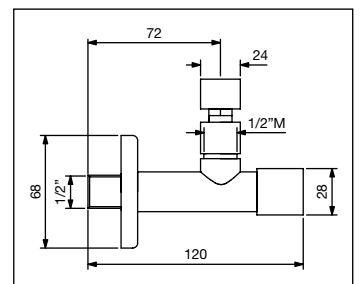

## RUBINETTI SOTTOLAVABO ANGLE VALVES

### RBF-1238

Rubinetto regolazione sottolavabo  
1/2" M x 3/8" M con filtro e rosetta

Angle valve tap 1/2" M x 3/8" M with filter  
and rosette

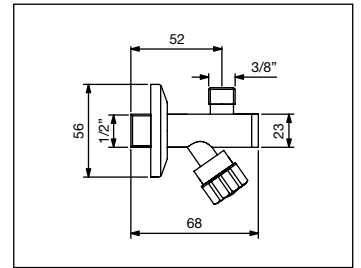

### RBF-1212-SN

Rubinetto regolazione sottolavabo  
1/2" M x 1/2" M con filtro, snodo e rosetta

Angle valve tap 1/2" M x 1/2" M with filter,  
joint and rosette

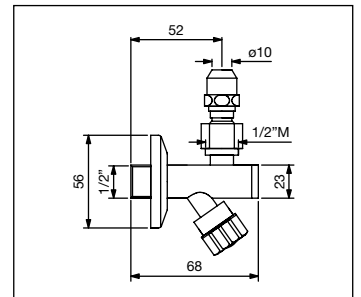

### V1238-ST

Rubinetto arresto sottolavabo STANDARD  
1/2" M x 3/8" M senza filtro con rosetta

STANDARD angle valve 1/2" M x 3/8" M  
without filter with rosette

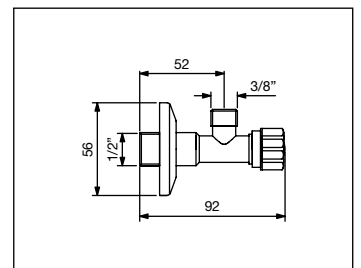

### V1212-ST

Rubinetto arresto sottolavabo STANDARD  
1/2" M x 1/2" M senza filtro con rosetta

STANDARD angle valve 1/2" M x 1/2" M  
without filter with rosette

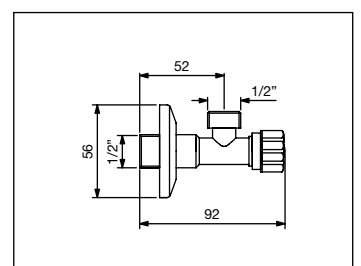

## RUBINETTI DI REGOLAZIONE ADJUSTMENT TAPS

### RB-WC-AL

Rubinetto regolazione per cassetta WC alta, completo di tubo  $\varnothing$  10 mm x 100 mm, prolunga in tubo ottone  $\varnothing$  10 mm x 150 mm con raccordo 3/8" saldato, rosetta e nipplo da 1/2"

Adjustment tap for high-mounted cistern, complete with pipe  $\varnothing$  10 mm x 100 mm, extension pipe  $\varnothing$  10 mm x 150 mm, welded fitting 3/8", rosette and nipple 1/2"

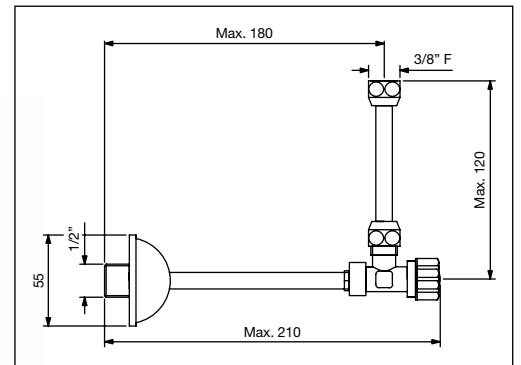
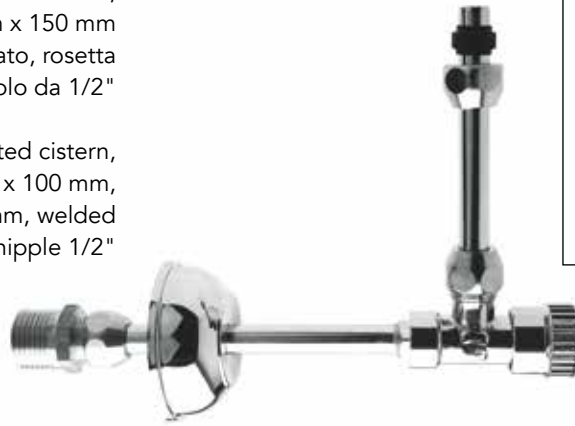

### V12-WC

Rubinetto regolazione 1/2" per cassetta WC zaino, completo di calotte, rosetta e tubo  $\varnothing$  10 mm x 100 mm

1/2" Adjustment tap for cistern, complete with nuts, rosette and pipe  $\varnothing$  10 mm x 100 mm

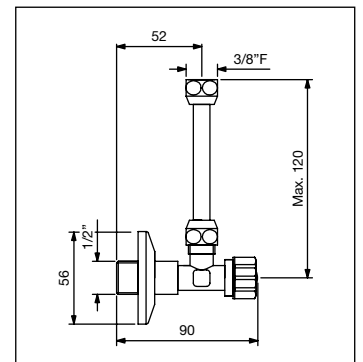

### V38-WC

Rubinetto regolazione 3/8" per cassetta WC zaino, completo di calotte, rosetta e tubo  $\varnothing$  10 mm x 100 mm

3/8" Adjustment tap for cistern, complete with nuts, rosette and pipe  $\varnothing$  10 mm x 100 mm

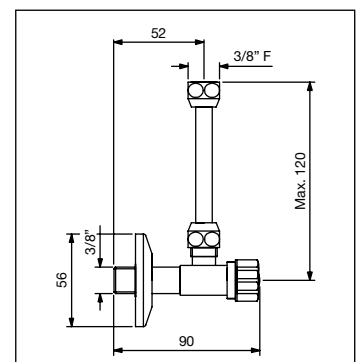

## RUBINETTI DI REGOLAZIONE ADJUSTMENT TAPS

### V105

Rubinetto regolazione 3/8" F per cassetta WC alta, completo di codolino 12/19 con calotta da 3/8"

3/8" F Adjustment tap for high-mounted cistern, complete with union 12/19 and 3/8" nut

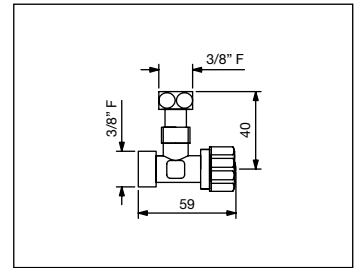

### V105P

Rubinetto regolazione per cassetta WC alta, completo di codolino, prolunga in tubo Ø 10 mm x 150 mm con raccordo da 3/8" saldato, nipplo da 1/2" e rosetta

Adjustment tap for high-mounted cistern, complete with union, extension pipe Ø 10 mm x 150 mm with 3/8" welded fitting, 1/2" nipple and rosette

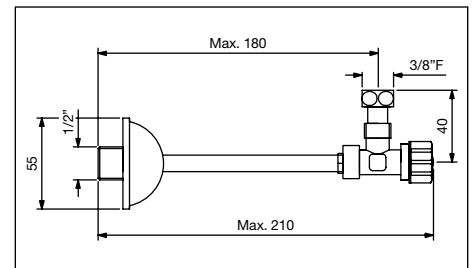

### RL34

Rubinetto a sfera 1/2" x 3/4" per lavatrice

Ball-tap for washing machine 1/2" x 3/4"

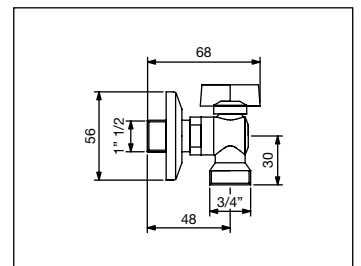

### RL1234

Rubinetto sottolavabo 1/2" M con rosetta, maniglia in ABS e calotta da 3/8".

Attacco sottolavabo per tubo Ø 10 mm e uscita attacco lavatrice 3/4" M

1/2" M angle valve tap, with rosette, ABS command knob and 3/8" washbasin connection with nut for pipe Ø 10 mm, 3/4" M connection for washing machine

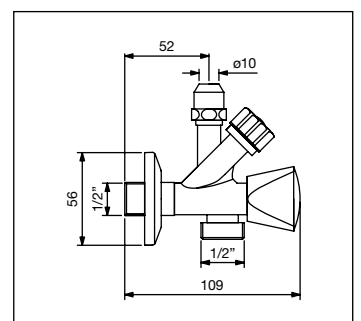







# IDROSCOPINO

## IDROSCOPINO

## DOCGETTA SHUT OFF SHUT OFF HANDSHOWER

### 01/SH

Doccetta shut off in ottone

Brass shut off hand shower

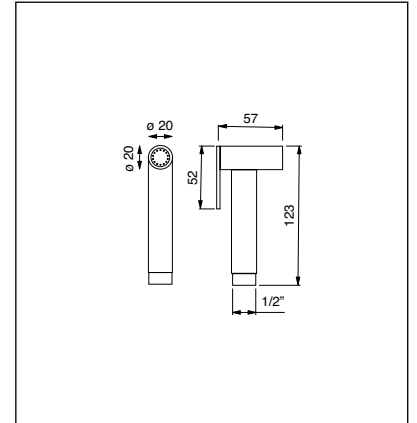

### VRM/SH

KIT rubinetto miscelatore  
con doccetta shut off  
e flessibile in ottone L = 150 mm

KIT mixer tap  
with shut off hand shower  
and brass flexible hose L = 150 mm

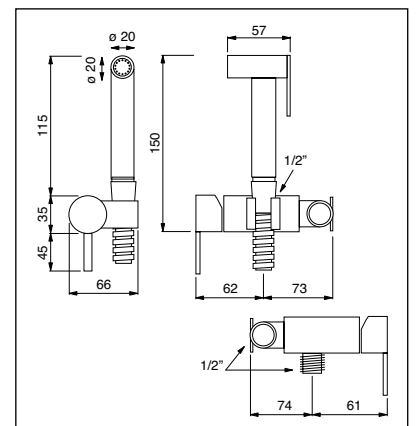

## KIT IDROSCOPINO IDROSCOPINO KIT

### VRA/SH

KIT idroscopino, rubinetto arresto  
con supporto, doccetta shut off  
e flessibile in ottone L = 120 mm

Idroscopino KIT, tap with support,  
shut off hand shower  
and brass flexible hose L = 120 mm

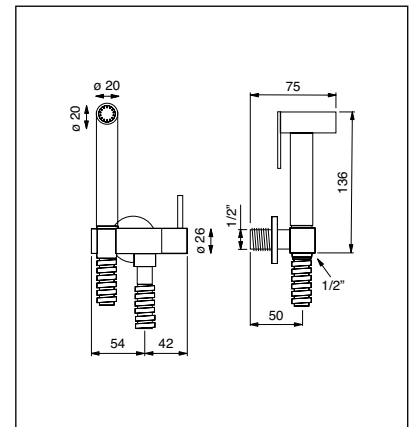

### VRT/SH

KIT idroscopino, rubinetto arresto,  
doccetta shut off con supporto a muro  
e flessibile in ottone L = 120 mm

Idroscopino KIT, tap, shut off hand shower  
with wall-mounted support  
and brass flexible hose L = 120 mm

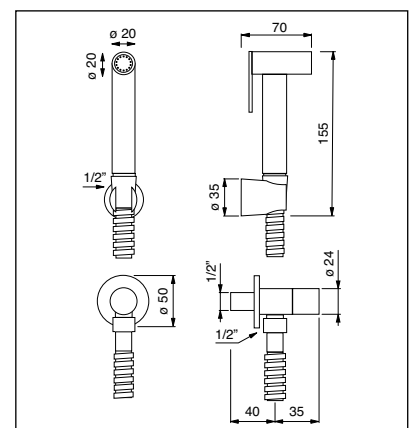





# SISTEMI DOCCIA

Shower systems

## PILETTE PER PIATTO DOCCIA SHOWER TRAY WASTES

### 836

Piletta di scarico 1" 1/2 con sifone estraibile per piatto doccia con foro Ø 90 mm

Shower tray waste 1" 1/2 with extractable trap for shower tray with outlet hole Ø 90 mm

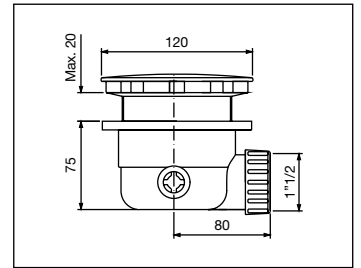

### 826

Piletta di scarico 1" 1/2 con sifone estraibile per piatto doccia con foro Ø 60 mm

Shower tray waste 1" 1/2 with extractable trap for shower tray with outlet hole Ø 60 mm

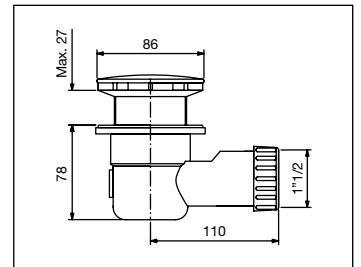

### 826-F50

Piletta di scarico 1" 1/2 con sifone estraibile per piatto doccia con foro Ø 50 mm

Shower tray waste 1" 1/2 with extractable trap for shower tray with outlet hole Ø 50 mm

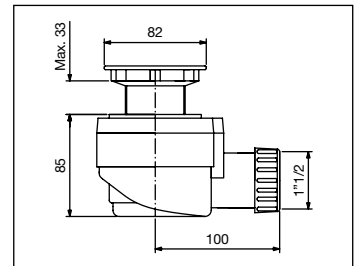

### 027

Raccordo curvo 45° in polipropilene con uscita Ø 40-50 mm

Connection tail 45° in polypropylene with outlet Ø 40-50 mm

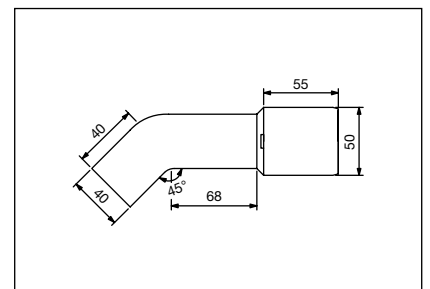

### 028

Tubo estensibile in polipropilene max. 950 mm con uscita Ø 32-40 mm

Extensible polypropylene pipe max. 950 mm with outlet Ø 32-40 mm

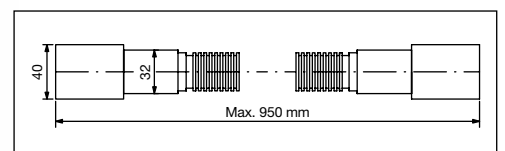

## PILETTE RIBASSATE PER PIATTO DOCCIA LOW SHOWER TRAY WASTES

### 836/SA

Piletta di scarico ribassata 1" 1/2 con sifone estraibile per piatto doccia con foro Ø 90 mm, flangia in plastica liscia, senza cover

Low shower tray waste 1" 1/2 with extractable trap for shower tray with outlet hole Ø 90 mm, flat plastic flange without cover

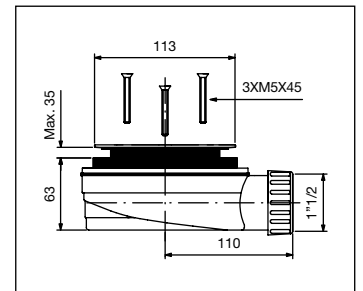

### 836/SAXF

Piletta di scarico ribassata 1" 1/2 con sifone estraibile per piatto doccia con foro Ø 90 mm, flangia in acciaio inox, senza cover

Low shower tray waste 1" 1/2 with extractable trap for shower tray with outlet hole Ø 90 mm, stainless steel flange without cover

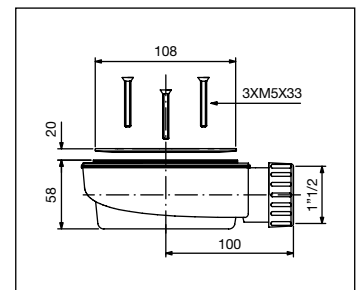

### 836/SACP

Piletta di scarico ribassata 1" 1/2 con sifone estraibile per piatto doccia con foro Ø 90 mm, con cover in ABS

Low shower tray waste 1" 1/2 with extractable trap for shower tray with outlet hole Ø 90 mm, with ABS cover

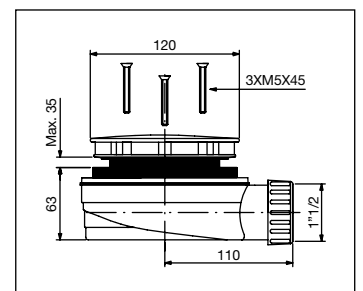

### 826/SACP

Piletta di scarico ribassata 1" 1/2 con sifone estraibile per piatto doccia con foro Ø 60 mm, con cover in ABS

Low shower tray waste 1" 1/2 with extractable trap for shower tray with outlet hole Ø 60 mm, with ABS cover

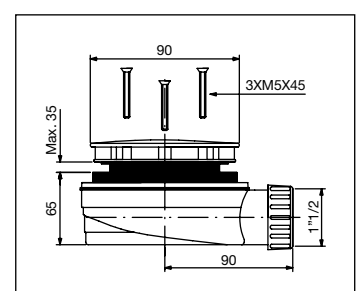



## SCARICHI A PAVIMENTO FLOOR DRAINS

### P875

Piletta a pavimento con sifone fisso,  
uscita Ø 40-50 mm e griglia  
100x100 mm in acciaio inox

Floor waste with fixed trap, outlet  
Ø 40-50 mm and 100x100 mm  
stainless steel grid

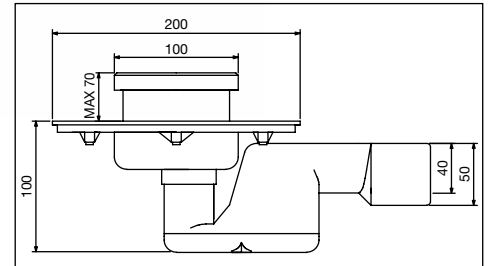

### PZ-01

Scarico a pavimento con sifone  
e uscita orizzontale Ø 50 mm  
- Griglia in acciaio inox 100x100 mm

Floor waste with trap and horizontal  
outlet Ø 50 mm - 100x100 mm  
stainless steel grid

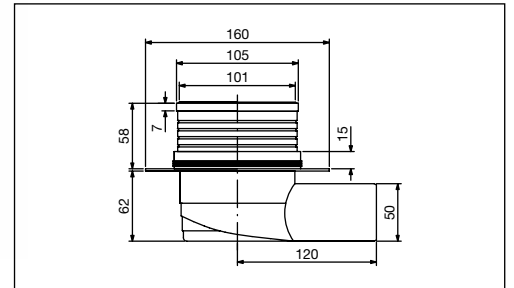

### PZ-03P

Scarico a pavimento con sifone e  
uscita orizzontale Ø 50 mm  
- PIASTRELLABILE

Floor waste with trap and horizontal  
outlet Ø 50 mm - TILEABLE

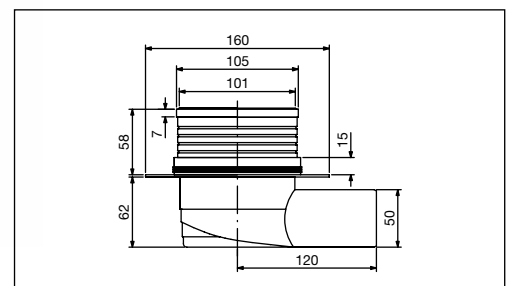

## SCARICHI RIBASSATI A PAVIMENTO LOW FLOOR DRAINS

### P870-DS1

Piletta ribassata a pavimento  
con griglia in ottone 100x100 mm  
- Design 1 Mod. EASY

Low floor waste  
with brass grid 100x100 mm  
- Design 1 Mod. EASY

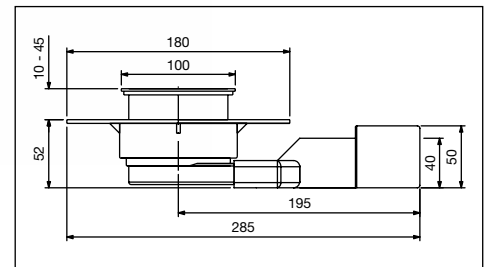

### P870-DS2

Piletta ribassata a pavimento  
con griglia in ottone 100x100 mm  
- Design 2 Mod. GRAFFITI

Low floor waste  
with brass grid 100x100 mm  
- Design 2 Mod. GRAFFITI

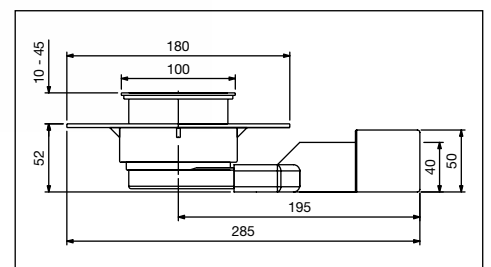



# DESIGN-PRO

Drain channels

**DESIGN 1**



**DESIGN-PRO**  
Canaline doccia

**DESIGN 3**

## CANALINE DI SCARICO "DESIGN-PRO" DRAIN CHANNELS "DESIGN-PRO"

Il corpo del canale di scarico è prodotto con materiale plastico di alta qualità e di grande durata, mentre la griglia "DESIGN-PRO" è fabbricata in acciaio inossidabile con superficie opaca.

Il sifone estraibile con elevata portata di scarico è facile da pulire e permette la pulizia meccanica dello scarico.

Otto (o quattro) piedini regolabili di supporto rendono l'installazione facile e veloce. Il collegamento tra il canale di scarico e lo strato di calcestruzzo che lo circonda è ottenuto con il nastro sigillante adesivo incluso nella confezione

The body of drain channel with gradient is made with high quality and durable plastic materials, while the "DESIGN-PRO" grid is made in stainless steel with matt surface.

The extractable siphon with high flow rate is easy to clean and allows mechanical cleaning of waste pipeline.

Eight (or four) adjustable supportive feet make the installation easier and faster.

The connection between drain channel and surrounding concrete layer is achieved by butylene self-adhesive sealing tape included with item

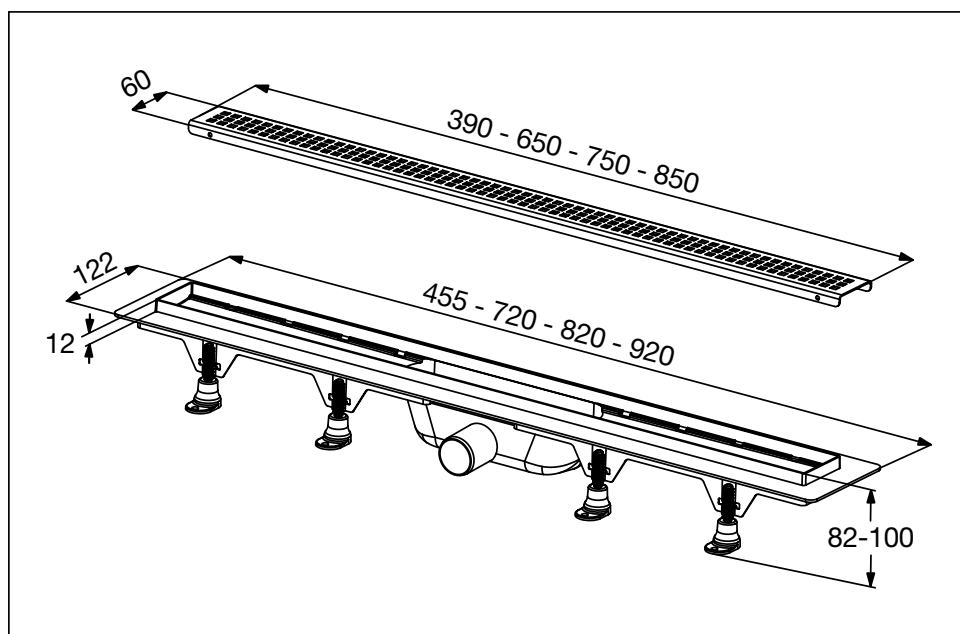

### INFORMAZIONI TECNICHE

Altezza della struttura: Min. 66 mm  
Flusso di scarico: 50 Lt/min  
Tubo di scarico: Ø 40 mm  
Materiale canalina: PP  
Materiale griglia: Acciaio INOX AISI 304  
Corpo di scarico con pendenza  
Sistema EASY-CLEAN per la pulizia  
Resistente agli agenti chimici per la pulizia  
EN 1253 – Classe di carico K3-300 Kg

### TECHNICAL DETAILS

Building height: Min. 66 mm  
Flow rate: 50 Lt/min  
Outlet connection: Ø 40 mm  
Material of drain: PP  
Material of grid: Stainless Steel AISI 304  
Drain body with slope  
EASY-CLEAN system  
Resistance to chemicals for purifications  
EN 1253 – Load class K3-300 Kg

## GRIGLIE "DESIGN-PRO" IN ACCIAIO INOX OPACO "DESIGN-PRO" MATT STAINLESS STEEL GRIDS

### DESIGN 1 - "FUTURE"

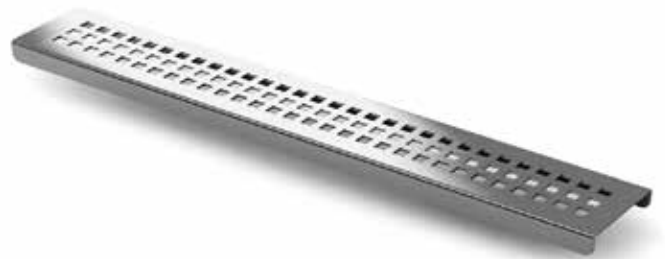

Disponibile in tutte le finiture

Available in all finishings

### DESIGN 2 - "EVOLUTION"



Disponibile in tutte le finiture

Available in all finishings

### DESIGN 3 - "MODERN" - Piastrellabile - Tileable



Codice Code	Dimensioni canalina Dimensions of channel	Dimensioni griglia Dimensions of grid
DP-400	455x122 mm	390x60 mm
DP-700	720x122 mm	650x60 mm
DP-800	820x122 mm	750x60 mm
DP-900	920x122 mm	850x60 mm

#### Contenuto della confezione:

Canalina doccia con griglia in acciaio, nastro autoadesivo sigillante, piedini regolabili, chiavetta per la pulizia e istruzioni di montaggio

#### Content box:

Drain channel with stainless steel grid, self-adhesive sealing tape, adjustable feet, clearing key and installation manual

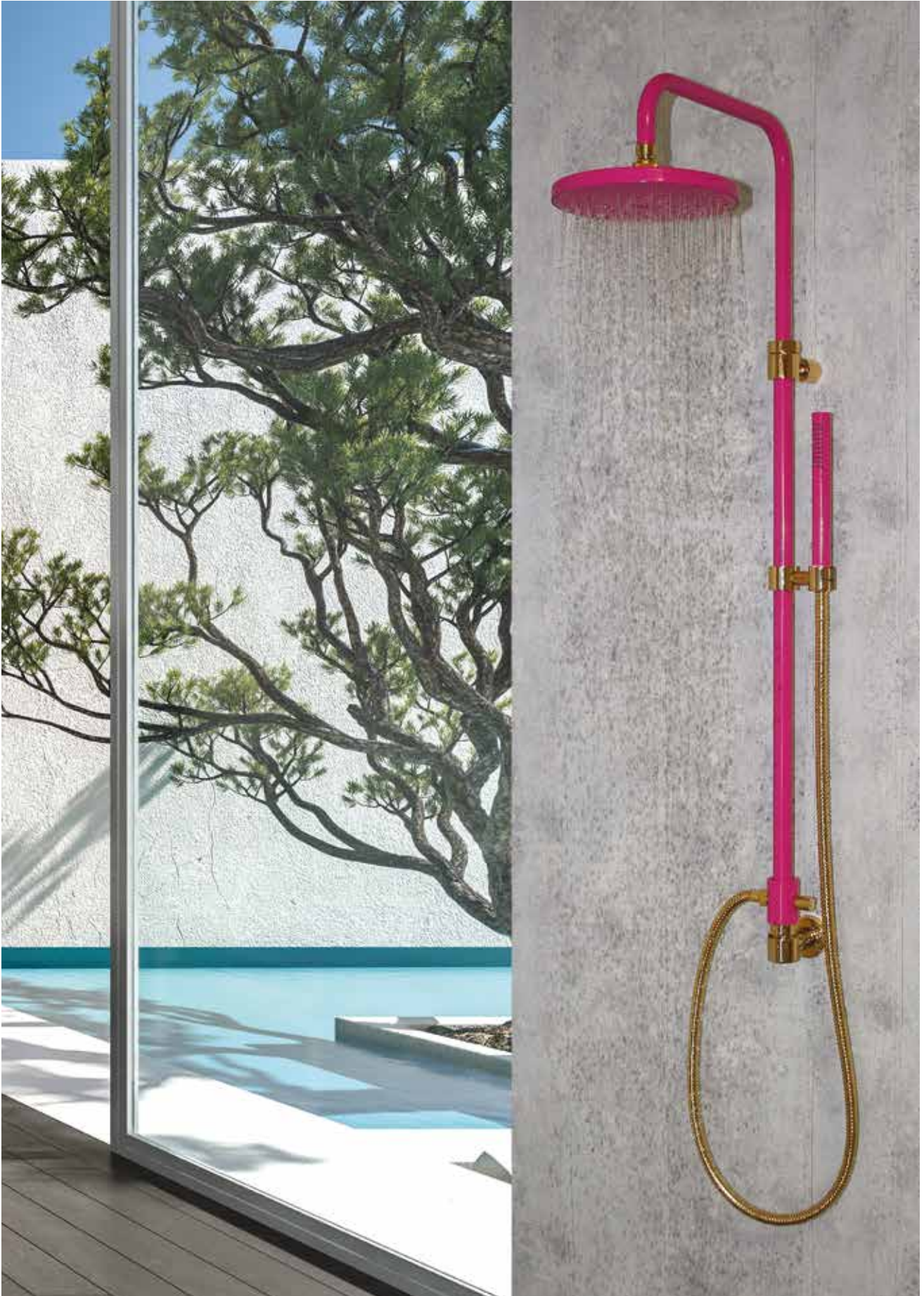

**PERFECTION AND DESIGN FOR PRECIOUS ENVIRONMENTS**



**PERFEZIONE E DESIGN PER AMBIENTI PREGIATI**



### 01261-KIT

Asta doccia STANDARD per ristrutturazione  
completa di soffione Art. 380,  
doccetta Art. 01/R e tubo flessibile

STANDARD stand pipe for restructuration  
complete of shower head Art. 380,  
handshower Art. 01/R and flexible hose



Disponibile in tutte le finiture  
Available in all finishings



# ASTA DOCCIA MODELLO "STANDARD" PER RISTRUTTURAZIONE "STANDARD" STAND PIPE FOR RESTRUCTURATION

**01261**

Asta doccia per ristrutturazione modello STANDARD con presa acqua alta, deviatore e supporto scorrevole

STANDARD stand pipe for restructuration with high water connection, diverter and sliding support



Preso acqua alta

High water connection



Gancio scorrevole

Sliding support



**Produzione SU MISURA a richiesta  
Tailor-made on request**

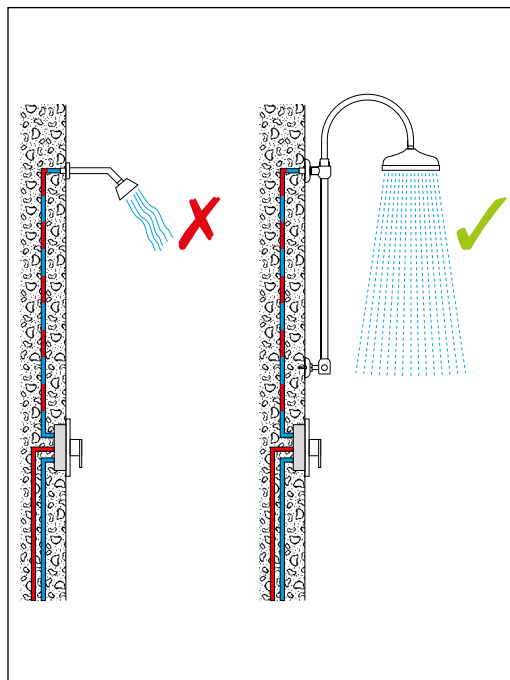
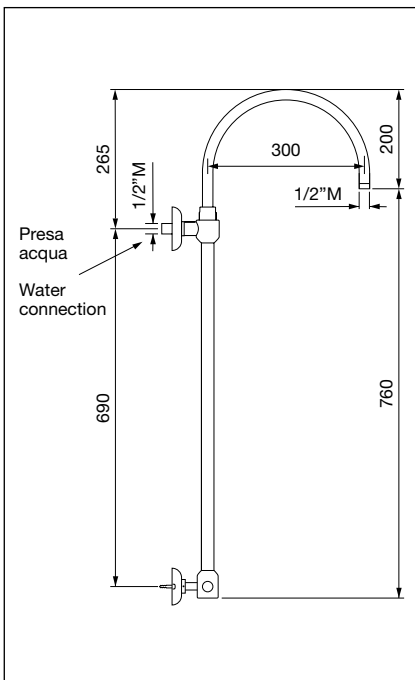

Installazione facile e veloce

Easy and fast installation



## 03261-KITH2

Asta doccia MINIMALISTA per ristrutturazione completa di soffione Art. R200-H2, doccetta Art. 01/T e tubo flessibile

MINIMALIST stand pipe for restructuration complete of shower head Art. R200-H2, handshower Art. 01/T and flexible hose



Disponibile in tutte le finiture  
Available in all finishings



# ASTA DOCCIA MODELLO "MINIMALISTA" PER RISTRUTTURAZIONE "MINIMALIST" STAND PIPE FOR RESTRUCTURATION

**03261**

Asta doccia per ristrutturazione modello  
MINIMALISTA con presa acqua alta, deviatore  
e supporto scorrevole

MINIMALIST stand pipe for restructuration  
with high water connection, diverter  
and sliding support



Preso acqua alta

High water connection



**Produzione SU MISURA a richiesta  
Tailor-made on request**

Gancio scorrevole

Sliding support

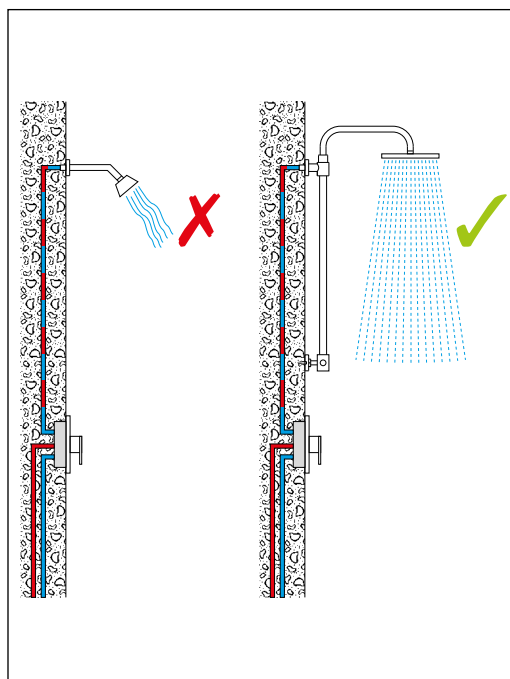
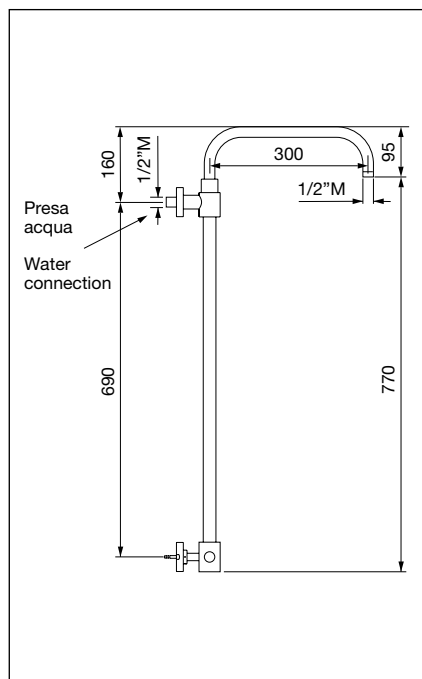

Installazione facile e veloce

Easy and fast installation



### 01161-KIT

Asta doccia telescopica ed orientabile modello STANDARD completa di soffione Art. 380, doccetta Art. 01/R e tubo flessibile

Telescopic and swivel stand pipe STANDARD model complete of shower head Art. 380, handshower Art. 01/R and flexible hose



Disponibile in tutte le finiture  
Available in all finishings

**Cod.../SHD**  
Gancio scorrevole a richiesta  
Sliding support on demand

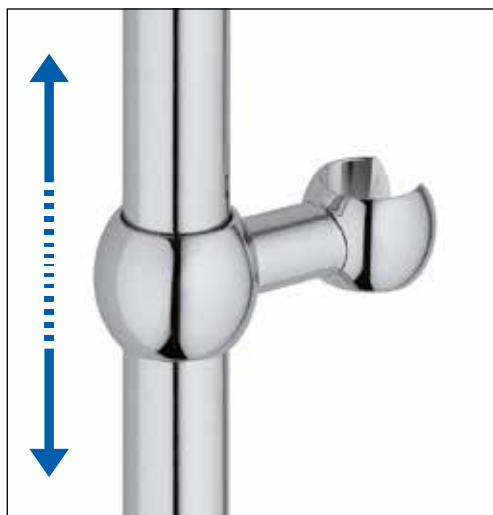

# ASTA DOCCIA MODELLO "STANDARD" STAND PIPE "STANDARD" MODEL

## 01160

Asta doccia telescopica ed orientabile  
modello STANDARD 640-1000 mm

Telescopic and swivel stand pipe STANDARD  
model 640-1000 mm

**Produzione SU MISURA a richiesta  
Tailor-made on request**

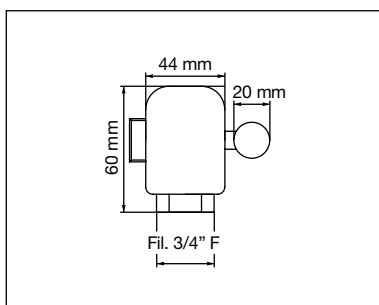
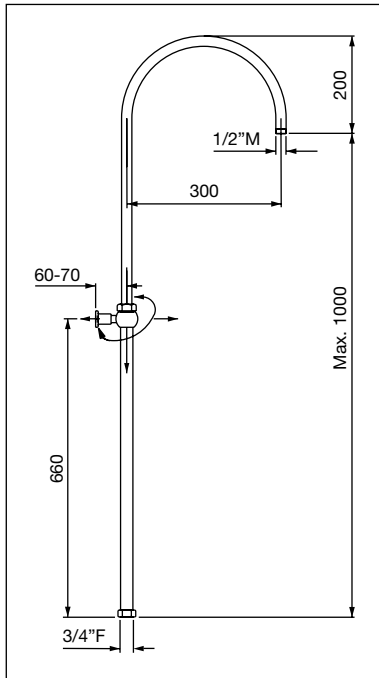

## 01161

Asta doccia telescopica ed orientabile  
modello STANDARD 640-1000 mm  
con deviatore e gancio

Telescopic and swivel stand pipe  
STANDARD model 640-1000 mm  
with diverter and support



### 02161-KIT

Asta doccia telescopica ed orientabile modello A PONTE completa di soffione Art. 380, doccetta Art. 01/R e tubo flessibile

Telescopic and swivel stand pipe BRIDGE model complete of shower head Art. 380, handshower Art. 01/R and flexible hose



Disponibile in tutte le finiture  
Available in all finishings

### Cod.../SHD

Gancio scorrevole a richiesta  
Sliding support on demand

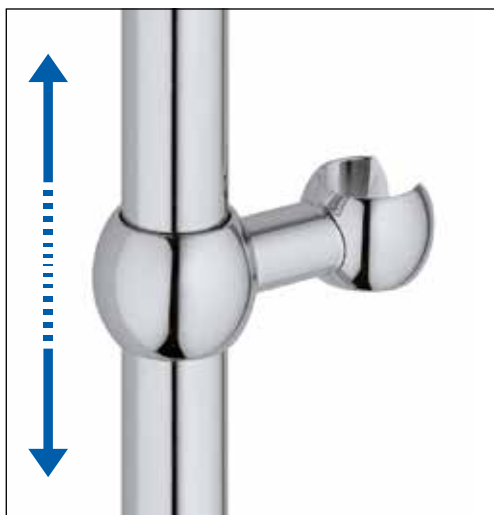

# ASTA DOCCIA MODELLO "A PONTE" STAND PIPE "BRIDGE" MODEL

## 02160

Asta doccia telescopica ed orientabile  
modello A PONTE 800-1100 mm

Telescopic and swivel stand pipe BRIDGE  
model 800-1100 mm

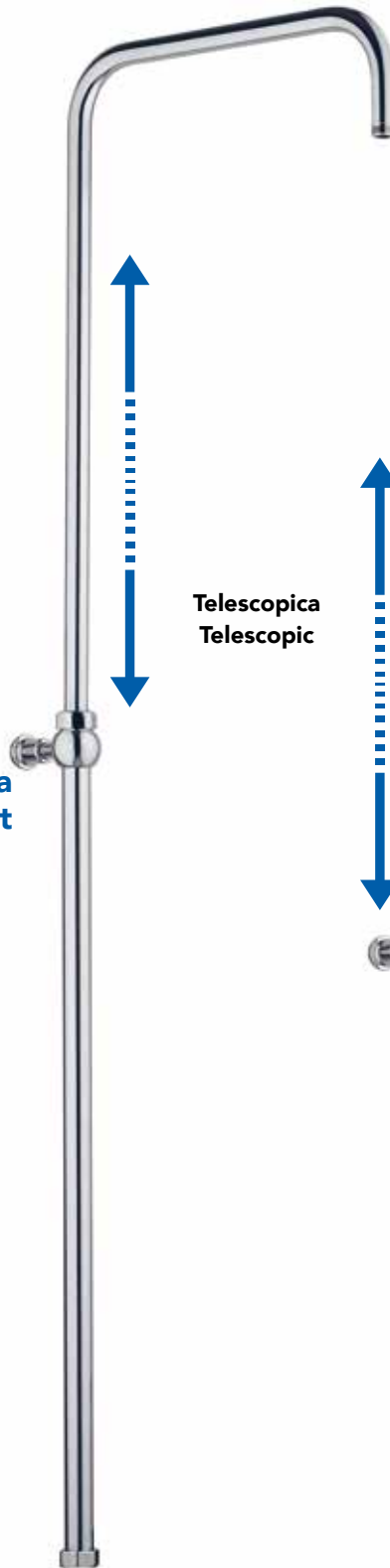

Telescopica  
Telescopic

## 02161

Asta doccia telescopica ed orientabile  
modello A PONTE 800-1100 mm  
con deviatore e gancio

Telescopic and swivel stand pipe  
BRIDGE model 800-1100 mm  
with diverter and support



**Produzione SU MISURA a richiesta**  
**Tailor-made on request**

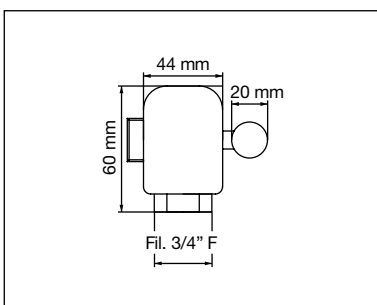
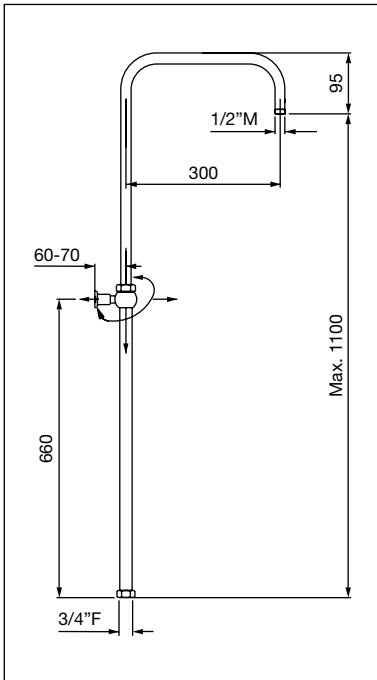



## 03161-KITH2

Asta doccia telescopica ed orientabile  
minimalista modello A PONTE completa  
di soffione Art. R200-H2, doccetta Art. 01/T  
e tubo flessibile

Minimalist telescopic and swivel stand pipe  
BRIDGE model complete of shower head  
Art. R200-H2, handshower Art. 01/T  
and flexible hose



Disponibile in tutte le finiture  
Available in all finishings

### Cod.../SHD

Gancio scorrevole a richiesta  
Sliding support on demand



# ASTA DOCCIA MINIMALISTA MODELLO "A PONTE" MINIMALIST STAND PIPE "BRIDGE" MODEL

## 03160

Asta doccia telescopica ed orientabile  
minimalista modello A PONTE 800-1100 mm

Minimalist telescopic and swivel stand pipe  
BRIDGE model 800-1100 mm

**Produzione SU MISURA a richiesta  
Tailor-made on request**

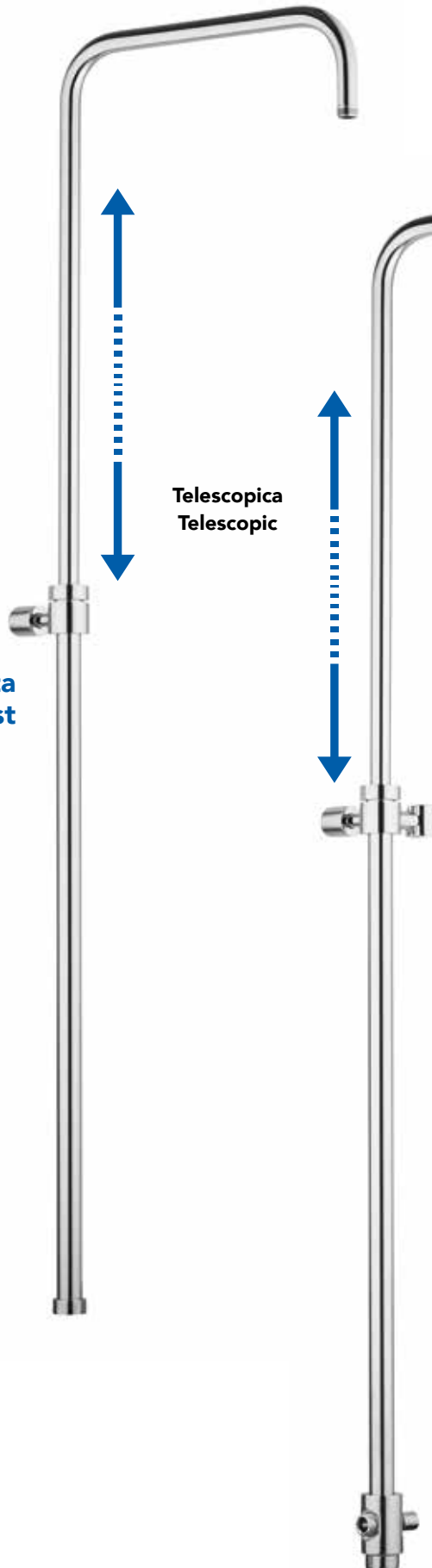
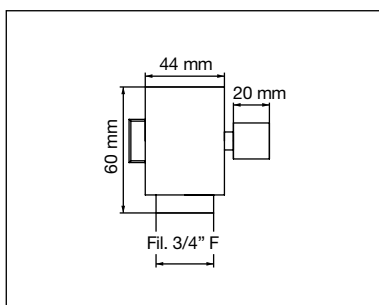
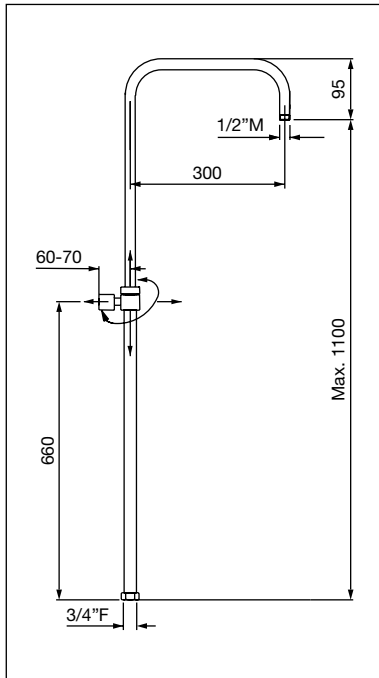

## 03161

Asta doccia telescopica ed orientabile  
minimalista modello A PONTE  
800-1100 mm con deviatore e gancio

Minimalist telescopic and swivel stand pipe  
BRIDGE model 800-1100 mm  
with diverter and support



## 04161-KITH2

Asta doccia modello QUADRATO completa  
di soffione Art. Q200-H2, doccetta  
Art. 01/Q e tubo flessibile

Stand pipe SQUARE model complete of  
shower head Art. Q200-H2, handshower  
Art. 01/Q and flexible hose



Disponibile in tutte le finiture  
Available in all finishings

### Cod.../SHD

Gancio scorrevole a richiesta  
Sliding support on demand

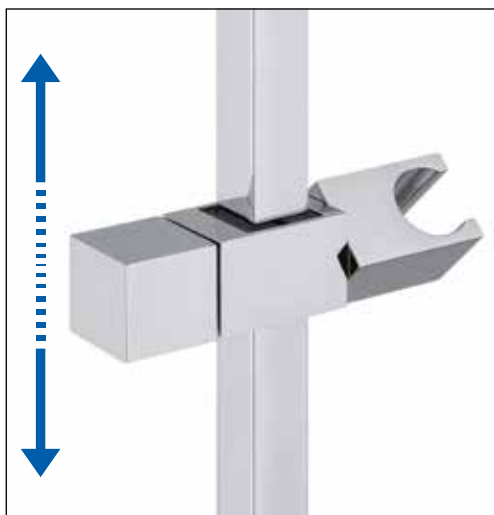

# ASTA DOCCIA MODELLO "QUADRATO" STAND PIPE "SQUARE" MODEL

## 04160

Asta doccia modello QUADRATO  
senza deviatore e gancio

Stand pipe SQUARE model without  
diverter and hook

**Produzione SU MISURA a richiesta**  
**Tailor-made on request**

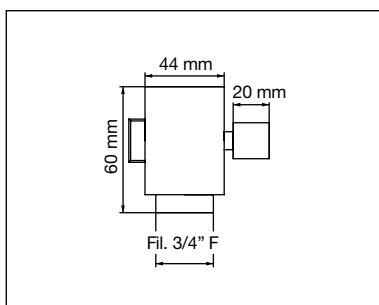
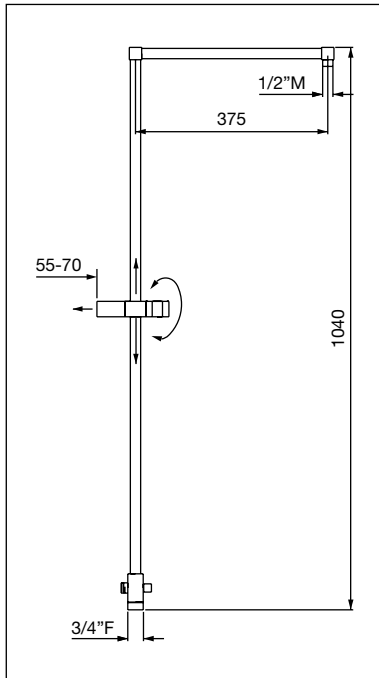

## 04161

Asta doccia modello QUADRATO  
con deviatore e gancio

Stand pipe SQUARE model with  
diverter and support



## 05161-KITH2

Asta doccia telescopica ed orientabile  
minimalista modello DRITTO completa  
di soffione Art. R200-H2, doccetta Art. 01/T  
e tubo flessibile

Minimalist telescopic and swivel stand pipe  
STRAIGHT model complete of shower head  
Art. R200-H2, handshower Art. 01/T  
and flexible hose



Disponibile in tutte le finiture  
Available in all finishings

### Cod.../SHD

Gancio scorrevole a richiesta  
Sliding support on demand



# ASTA DOCCIA MINIMALISTA MODELLO "DRITTO" MINIMALIST STAND PIPE "STRAIGHT" MODEL

## 05160

Asta doccia telescopica ed orientabile  
minimalista modello DRITTO 800-1170 mm

Minimalist telescopic and swivel stand pipe  
STRAIGHT model 800-1170 mm

**Produzione SU MISURA a richiesta**  
**Tailor-made on request**

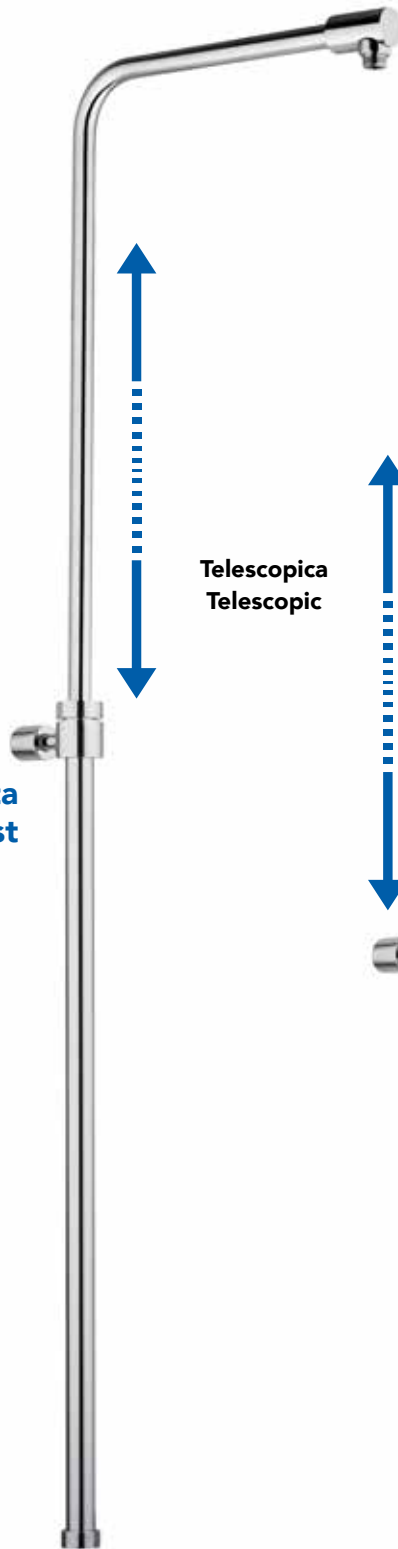
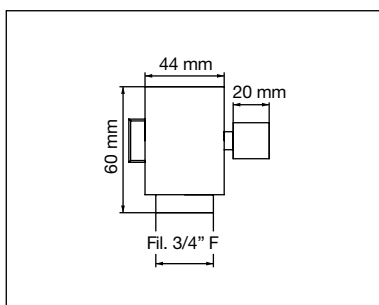
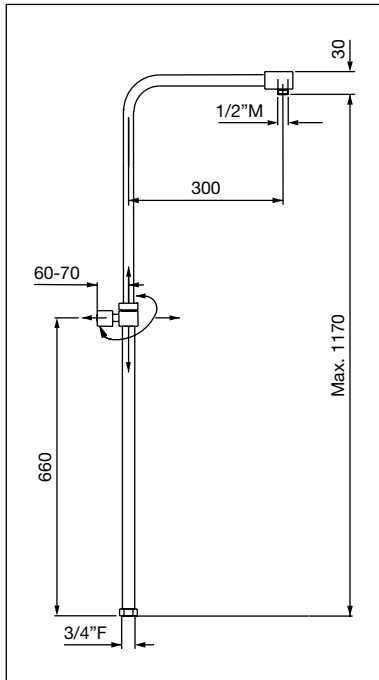

**Telescopica**  
**Telescopic**

## 05161

Asta doccia telescopica ed orientabile  
minimalista modello DRITTO  
800-1170 mm con deviatore e gancio

Minimalist telescopic and swivel stand pipe  
STRAIGHT model 800-1170 mm  
with diverter and support



## 06161-KITH2

Asta doccia telescopica ed orientabile  
minimalista modello A SPIGOLI completa  
di soffione Art. Q200-H2, doccetta  
Art. 01/Q e tubo flessibile

Minimalist telescopic and swivel stand pipe  
CORNERS model complete of shower head  
Art. Q200-H2, handshower Art. 01/Q  
and flexible hose



Disponibile in tutte le finiture  
Available in all finishings

### Cod.../SHD

Gancio scorrevole a richiesta  
Sliding support on demand



# ASTA DOCCIA MINIMALISTA MODELLO "A SPIGOLI" MINIMALIST STAND PIPE "CORNERS" MODEL

## 06160

Asta doccia telescopica ed orientabile  
minimalista modello A SPIGOLI 800-1100 mm

Minimalist telescopic and swivel stand pipe  
CORNERS model 800-1100 mm

**Produzione SU MISURA a richiesta**  
**Tailor-made on request**

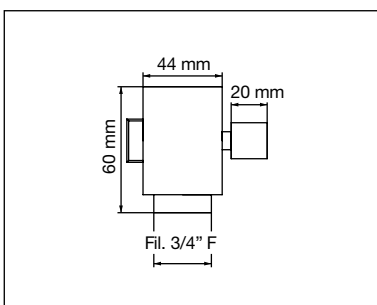
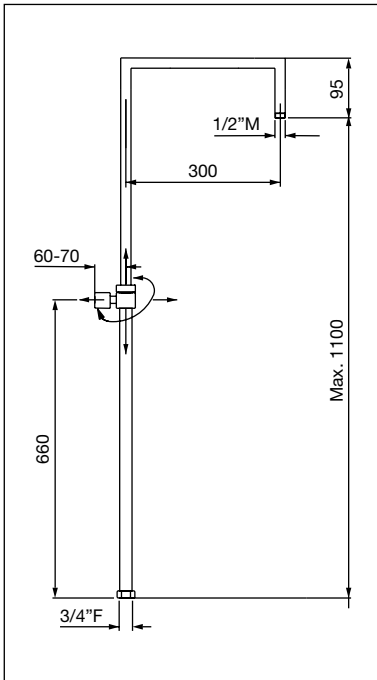

## 06161

Asta doccia telescopica ed orientabile  
minimalista modello A SPIGOLI  
800-1100 mm con deviatore e gancio

Minimalist telescopic and swivel stand pipe  
CORNERS model 800-1100 mm  
with diverter and support







## PRESE ACQUA PER COLONNA DOCCIA WATER CONNECTIONS FOR SHOWER COLUMN

### 0116

Pres a acqua per colonna doccia,  
attacchi 1/2" M x 3/4" M

Water connection for shower column,  
connections 1/2" M x 3/4" M

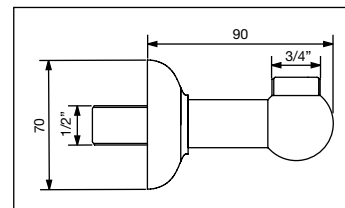

### 0117

Pres a acqua minimalista per colonna  
doccia, attacchi 1/2" M x 3/4" M

Minimalist water connection for shower  
column, connections 1/2" M x 3/4" M

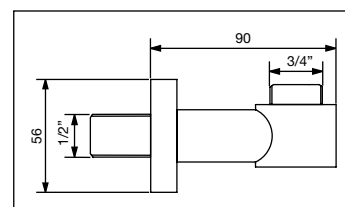

### 0119

Pres a acqua quadrata per colonna  
doccia, attacchi 1/2" M x 3/4" M

Square water connection for shower  
column, connections 1/2" M x 3/4" M

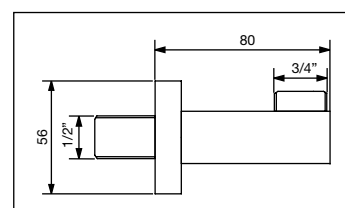

### 0118

Supporto per colonna doccia con  
connessione 1/2" M per tubo flessibile

Support for shower column with  
connection 1/2" M for flexible hose

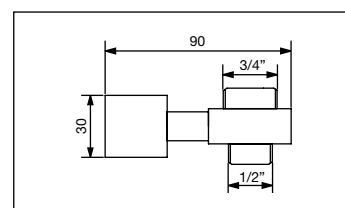



# KIT COMPLETO ASTA DOCCIA MODERNA COMPLETE MODERN SHOWER COLUMN SET

## ATE-KIT

- Asta doccia moderna cromata
  - Soffione ABS Ø 200 mm con sistema anticalcare
  - Doccetta ABS multifunzione a 5 getti con sistema anticalcare
  - 2 staffe a muro regolabili in ABS
  - Supporto saliscendi ABS regolabile e orientabile con pulsante di sblocco
  - 2 flessibili in ottone a doppia aggraffatura  
L = 150 cm per doccetta  
L = 60 cm per presa acqua
  - Deviatore a leva in ottone
  - Vassoio portasapone
- Modern chromed shower column
  - ABS shower head Ø 200 mm with antilimestone system
  - ABS handshower 5 jets with antilimestone system
  - 2 adjustable ABS wall supports
  - ABS slider support with unlock button
  - 2 brass flexible hoses double seam  
L = 150 cm for handshower  
L = 60 cm for water connection
  - Brass diverter with leverage
  - Soapdish

# Atena

Ø 200 mm ABS



Cod.../SM

Staffe in metallo a richiesta  
Metal wall supports on demand

**FACILE  
INSTALLAZIONE**  
**EASY  
INSTALLATION**

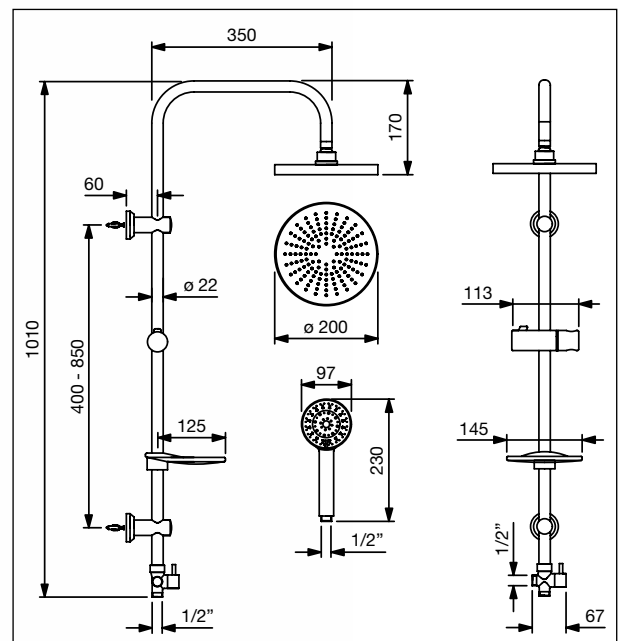
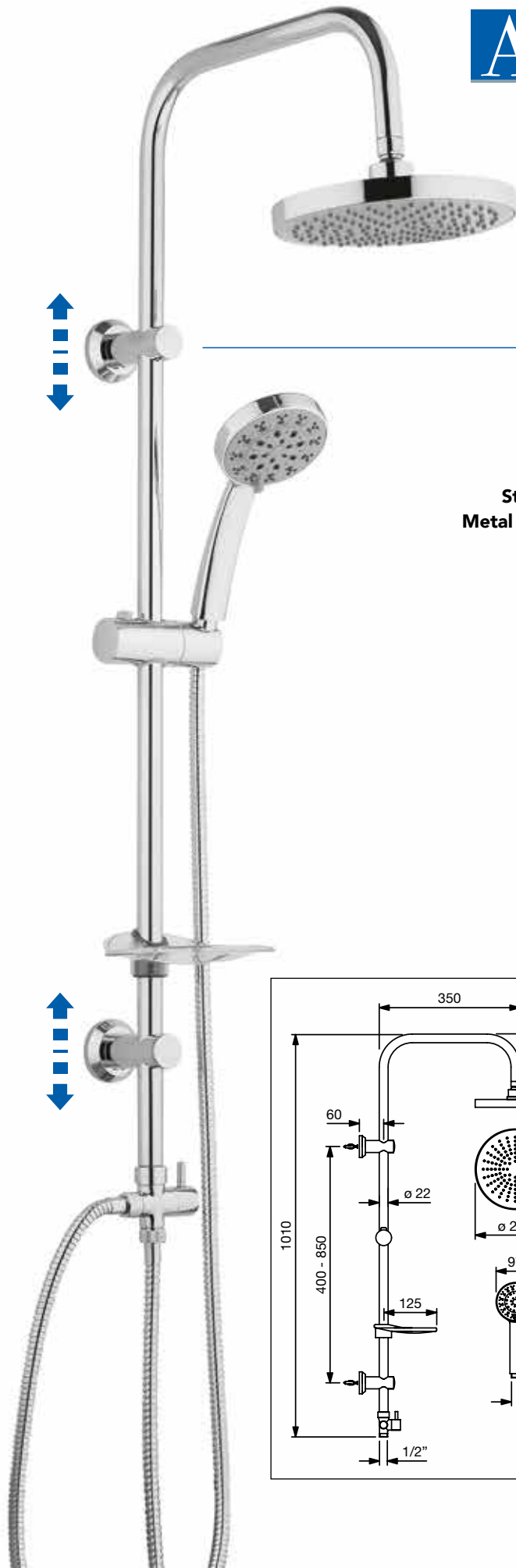

# KIT COMPLETO ASTA DOCCIA MODERNA COMPLETE MODERN SHOWER COLUMN SET

## ATE-KIT200H2

- Asta doccia moderna cromata
  - Soffione in acciaio Ø 200 mm H2 con sistema anticalcare e valvola di sicurezza
  - Doccetta ABS multifunzione a 5 getti con sistema anticalcare
  - 2 staffe a muro regolabili in ABS
  - Supporto saliscendi ABS regolabile e orientabile con pulsante di sblocco
  - 2 flessibili in ottone a doppia aggraffatura  
L = 150 cm per doccetta  
L = 60 cm per presa acqua
  - Deviatore a leva in ottone
  - Vassoio portasapone
- Modern chromed shower column
  - Stainless steel shower head Ø 200 mm H2 with antilimestone system and safety valve
  - ABS handshower 5 jets with antilimestone system
  - 2 adjustable ABS wall supports
  - ABS slider support with unlock button
  - 2 brass flexible hoses double seam  
L = 150 cm for handshower  
L = 60 cm for water connection
  - Brass diverter with leverage
  - Soapdish

# Atena

Ø 200 mm INOX



Cod.../SM

Staffe in metallo a richiesta  
Metal wall supports on demand

**FACILE  
INSTALLAZIONE**  
**EASY  
INSTALLATION**

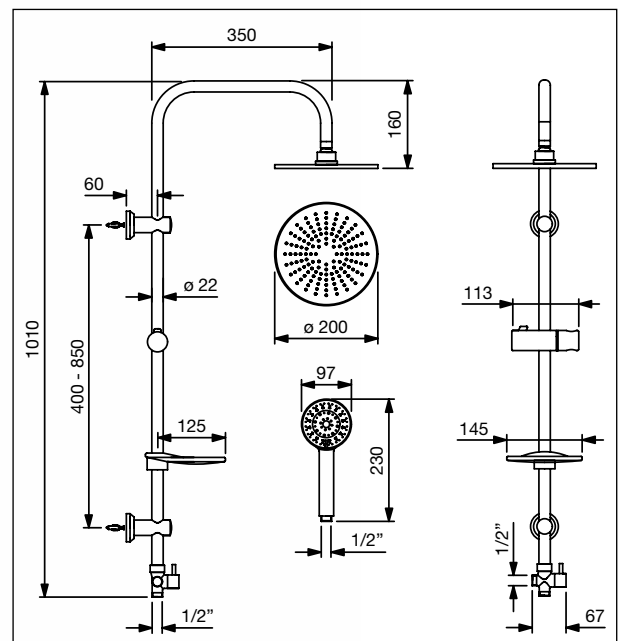

# KIT COMPLETO ASTA DOCCIA MODERNA COMPLETE MODERN SHOWER COLUMN SET

## ATE-KIT250H2

- Asta doccia moderna cromata
- Soffione in acciaio Ø 250 mm H2 con sistema anticalcare e valvola di sicurezza
- Doccetta ABS multifunzione a 5 getti con sistema anticalcare
- 2 staffe a muro regolabili in ABS
- Supporto saliscendi ABS regolabile e orientabile con pulsante di sblocco
- 2 flessibili in ottone a doppia aggraffatura  
L = 150 cm per doccetta  
L = 60 cm per presa acqua
- Deviatore a leva in ottone
- Vassoio portasapone

- Modern chromed shower column
- Stainless steel shower head Ø 250 mm H2 with antilimestone system and safety valve
- ABS handshower 5 jets with antilimestone system
- 2 adjustable ABS wall supports
- ABS slider support with unlock button
- 2 brass flexible hoses double seam  
L = 150 cm for handshower  
L = 60 cm for water connection
- Brass diverter with leverage
- Soapdish

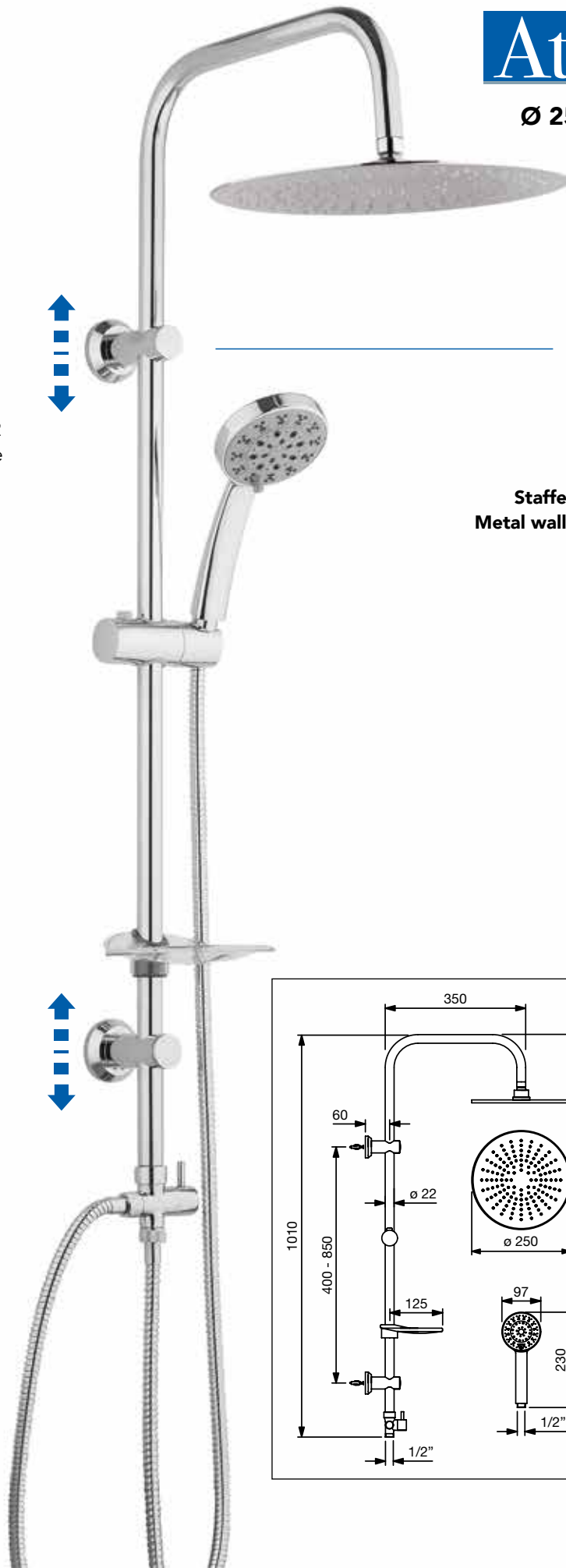

# Atena

Ø 250 mm INOX



**Cod.../SM**

**Staffe in metallo a richiesta  
Metal wall supports on demand**

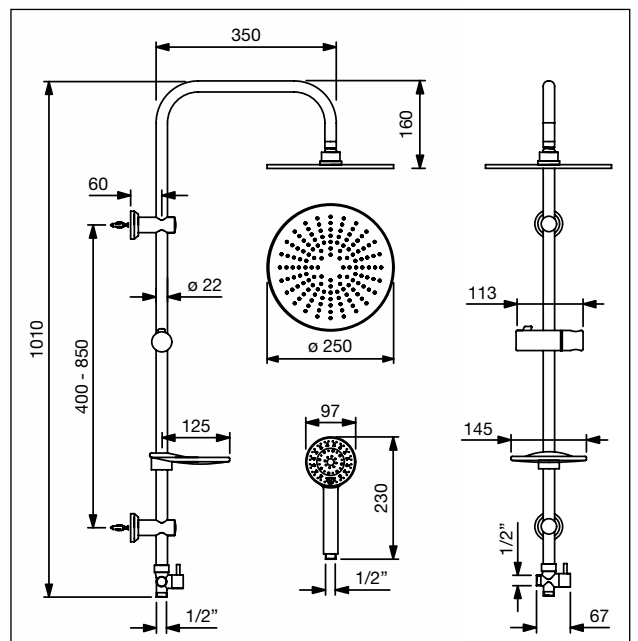



# KIT COMPLETO ASTA DOCCIA MODERNA COMPLETE MODERN SHOWER COLUMN SET

## DIA-KIT

- Asta doccia moderna cromata
  - Soffione ABS 200x200 mm con sistema anticalcare
  - Doccetta ABS quadrata a 1 getto con sistema anticalcare
  - 2 staffe a muro regolabili in ABS
  - Supporto saliscendi ABS regolabile e orientabile con pulsante di sblocco
  - 2 flessibili in ottone a doppia aggiratura  
L = 150 cm per doccetta  
L = 60 cm per presa acqua
  - Deviatore a leva in ottone
  - Vassoio portasapone
- Modern chromed shower column
  - ABS shower head 200x200 mm with antilimestone system
  - ABS square handshower 1 jet with antilimestone system
  - 2 adjustable ABS wall supports
  - ABS slider support with unlock button
  - 2 brass flexible hoses double seam  
L = 150 cm for handshower  
L = 60 cm for water connection
  - Brass diverter with leverage
  - Soapdish

# Diana

200x200 mm ABS



Cod.../SM

Staffe in metallo a richiesta  
Metal wall supports on demand

**FACILE  
INSTALLAZIONE**  
**EASY  
INSTALLATION**

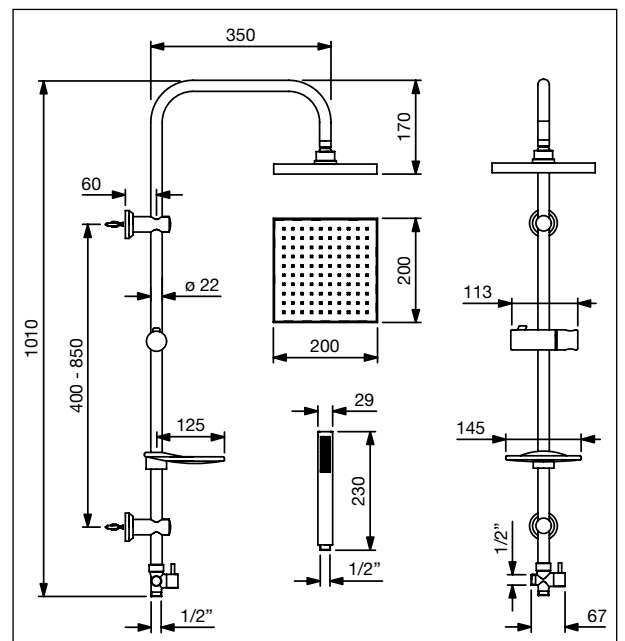
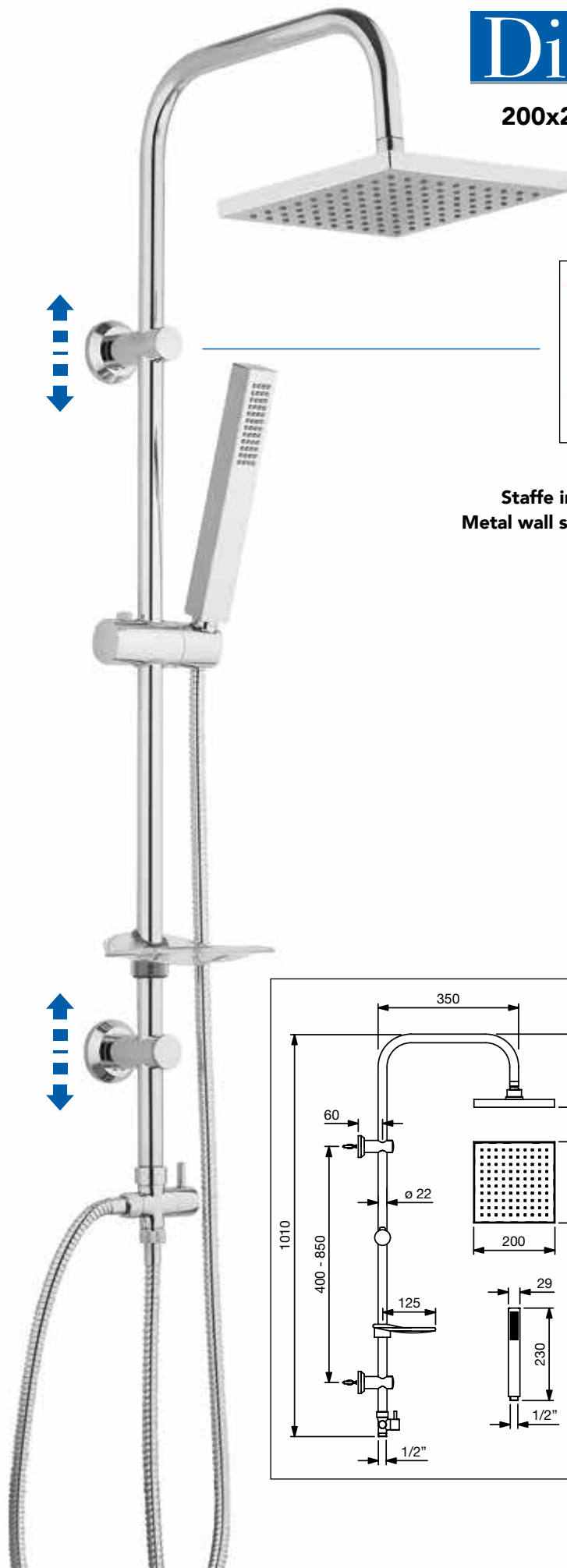



# KIT COMPLETO ASTA DOCCIA MODERNA COMPLETE MODERN SHOWER COLUMN SET

## DIA-KIT200H2

- Asta doccia moderna cromata
- Soffione in acciaio 200x200 mm H2 con sistema anticalcare e valvola di sicurezza
- Doccetta ABS quadrata a 1 getto con sistema anticalcare
- 2 staffe a muro regolabili in ABS
- Supporto saliscendi ABS regolabile e orientabile con pulsante di sblocco
- 2 flessibili in ottone a doppia aggraffatura  
L = 150 cm per doccetta  
L = 60 cm per presa acqua
- Deviatore a leva in ottone
- Vassoio portasapone

- Modern chromed shower column
- Stainless steel shower head 200x200 mm H2 with antilimestone system and safety valve
- ABS square handshower 1 jet with antilimestone system
- 2 adjustable ABS wall supports
- ABS slider support with unlock button
- 2 brass flexible hoses double seam  
L = 150 cm for handshower  
L = 60 cm for water connection
- Brass diverter with leverage
- Soapdish

# Diana

200x200 mm INOX



Cod.../SM

Staffe in metallo a richiesta  
Metal wall supports on demand

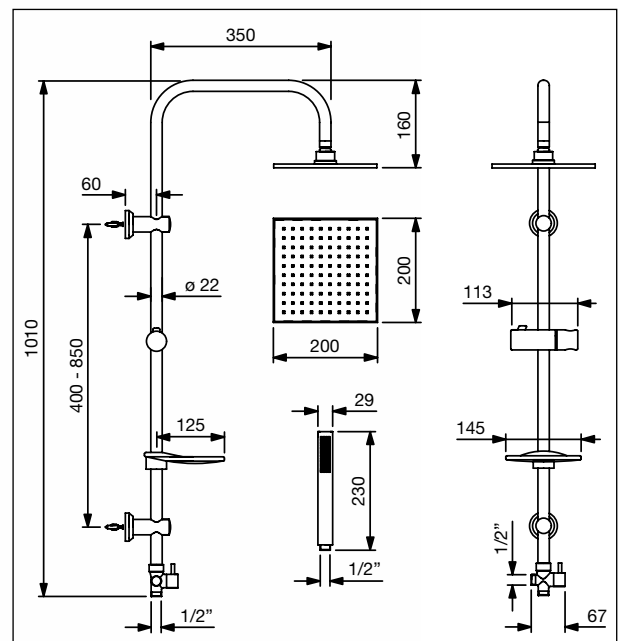
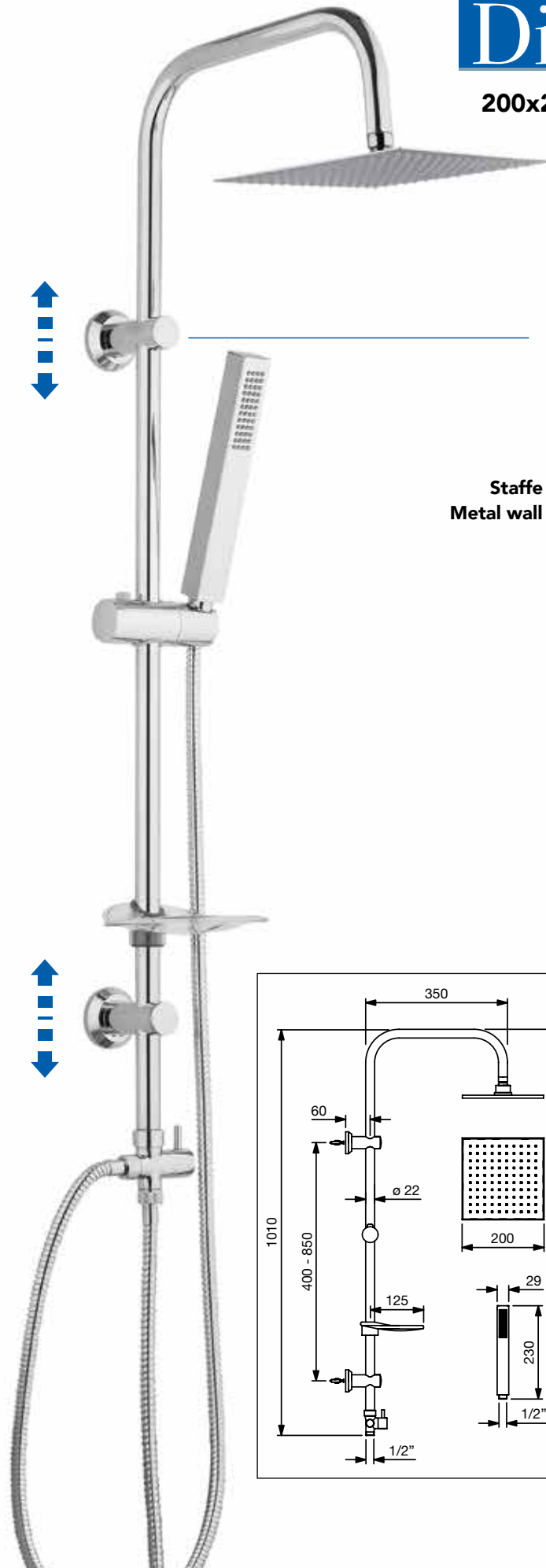

# KIT COMPLETO ASTA DOCCIA MODERNA COMPLETE MODERN SHOWER COLUMN SET

## DIA-KIT250H2

- Asta doccia moderna cromata
- Soffione in acciaio 250x250 mm H2 con sistema anticalcare e valvola di sicurezza
- Doccetta ABS quadrata a 1 getto con sistema anticalcare
- 2 staffe a muro regolabili in ABS
- Supporto saliscendi ABS regolabile e orientabile con pulsante di sblocco
- 2 flessibili in ottone a doppia aggraffatura  
L = 150 cm per doccetta  
L = 60 cm per presa acqua
- Deviatore a leva in ottone
- Vassoio portasapone

- Modern chromed shower column
- Stainless steel shower head 250x250 mm H2 with antilimestone system and safety valve
- ABS square handshower 1 jet with antilimestone system
- 2 adjustable ABS wall supports
- ABS slider support with unlock button
- 2 brass flexible hoses double seam  
L = 150 cm for handshower  
L = 60 cm for water connection
- Brass diverter with leverage
- Soapdish

# Diana

250x250 mm INOX



Cod.../SM

Staffe in metallo a richiesta  
Metal wall supports on demand

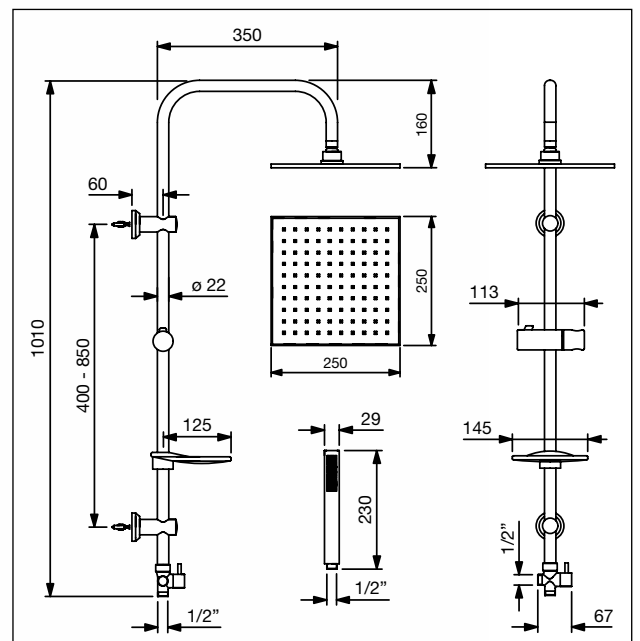
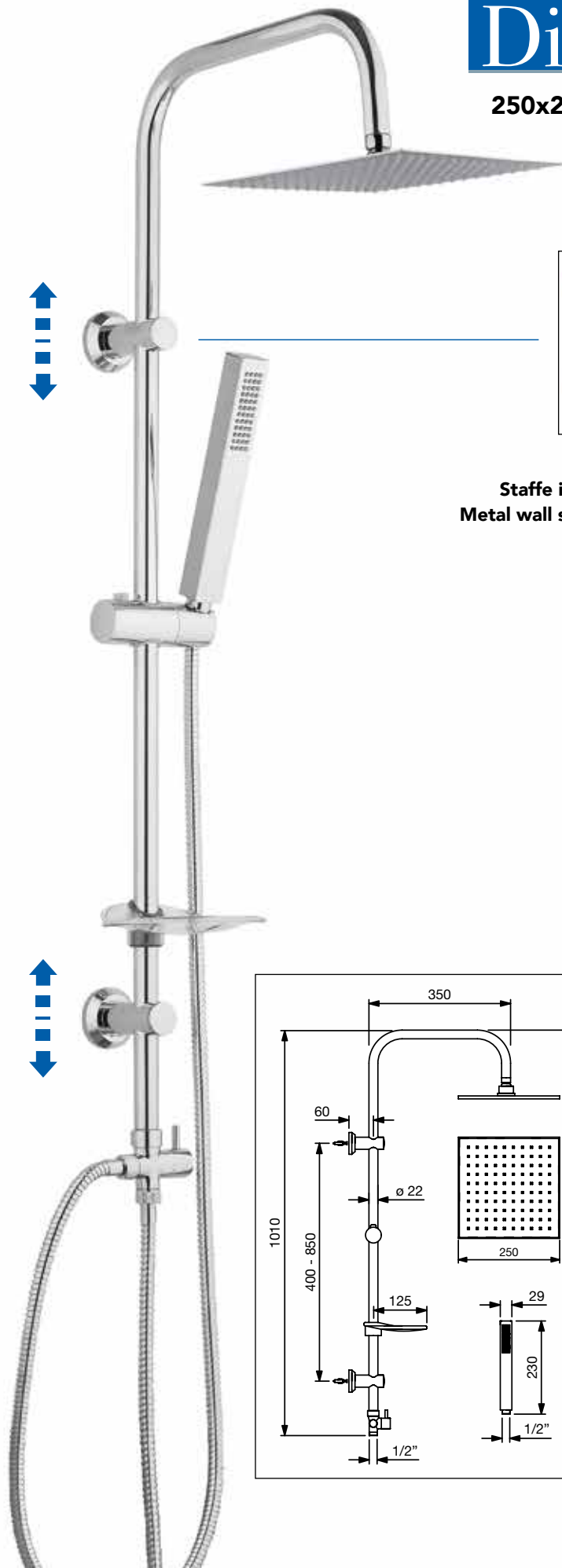



## KIT COMPLETO SALISCENDI MODERNO COMPLETE MODERN SLIDING RAIL SET

# Olivia

### OLI-KIT

- Saliscendi completo cromato L = 760 mm
  - Doccetta ABS multifunzione a 5 getti con sistema anticalcare
  - 1 staffa a muro fissa + 1 staffa regolabile
  - Supporto saliscendi ABS regolabile e orientabile con pulsante di sblocco
  - 1 flessibile in ottone a doppia aggraffatura L = 150 cm per doccetta
  - Vassoio portasapone
- 
- Chromed shower set with sliding rail L = 760 mm
  - ABS handshower 5 jets with antilimestone system
  - 1 adjustable wall support + 1 fixed wall support
  - ABS slider support with unlock button
  - 1 brass flexible hose double seam L=150 cm for handshower
  - Soapdish

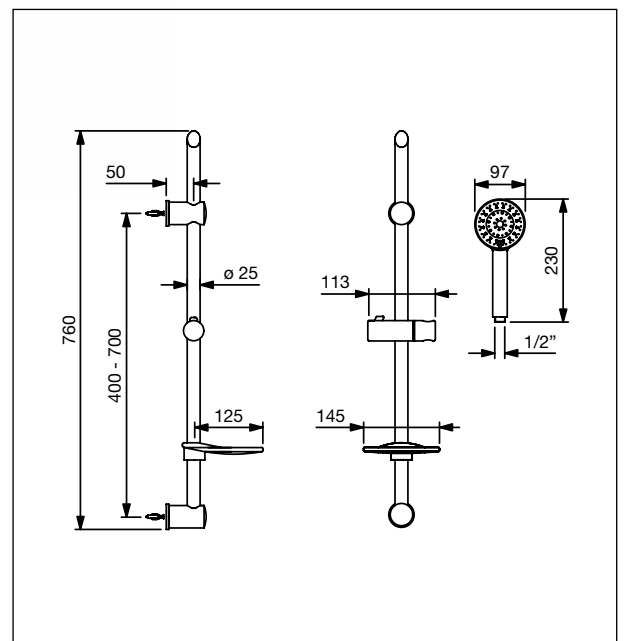

### **385-KIT**

KIT completo soffione design conico  
con braccio doccia, tutto in ottone

Complete KT conical design shower head  
with shower arm, all in brass



**Disponibile in tutte le finiture**  
**Available in all finishings**



## KIT SOFFIONE DESIGN KIT DESIGN SHOWER HEAD

### 385

Soffione design conico ispezionabile in ottone Ø 200 mm con snodo 1/2" F

Conical design demountable brass shower head Ø 200 mm with joint 1/2" F

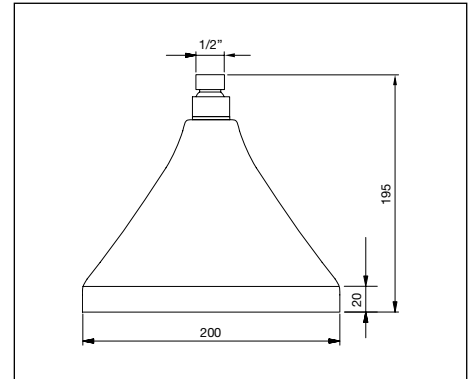

### 385/A

Soffione design conico ispezionabile in ottone Ø 200 mm sistema anticalcare e con snodo 1/2" F

Conical design demountable brass shower head Ø 200 mm with antilimestone system and joint 1/2" F

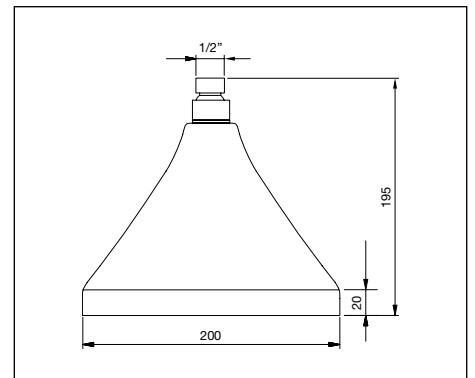

### 485

Braccio doccia speciale per soffione serie 385

Special shower arm for shower head serie 385

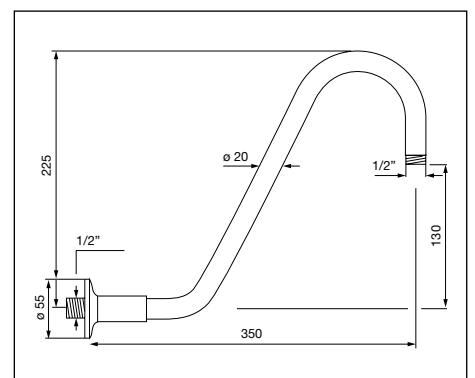

## SOFFIONE ISPEZIONABILE + BRACCIO DEMOUNTABLE SHOWER HEAD + SHOWER ARM

Soffione ISPEZIONABILE Art. 380 in ottone  
+ braccio Art. 480

DEMOUNTABLE brass shower head Art. 380  
+ shower arm Art. 480

Codice Code	Soffione Shower head	Braccio Shower arm
380.30	Ø 200 mm	300 mm
380.35	Ø 200 mm	350 mm
380.40	Ø 200 mm	400 mm
381.35	Ø 300 mm	350 mm
381.40	Ø 300 mm	400 mm



Soffione ISPEZIONABILE Art. 382 in ottone  
+ braccio Art. 480

DEMOUNTABLE brass shower head Art. 382  
+ shower arm Art. 480

Codice Code	Soffione Shower head	Braccio Shower arm
382.30	Ø 200 mm	300 mm
382.35	Ø 200 mm	350 mm
382.40	Ø 200 mm	400 mm



**Disponibile in tutte le finiture**  
**Available in all finishings**

Un sistema innovativo del getto ne caratterizza il costante flusso anche ad una minima pressione dell'acqua

An innovating jet system to get an uniform water flow also at low water pressure

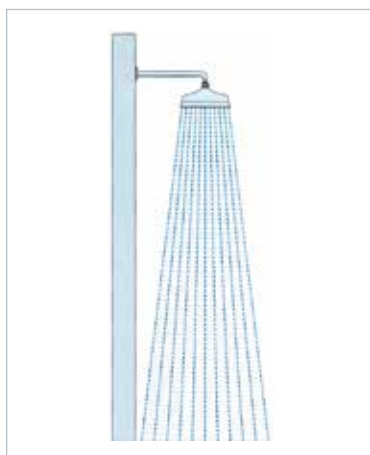

Filtro ispezionabile

Demountable filter



## SOFFIONE ABS + BRACCIO ABS SHOWER HEAD + SHOWER ARM

Soffione in ABS Art. 382/ABS + braccio Art. 481

ABS shower head Art. 382/ABS + shower arm Art. 481

<b>Codice Code</b>	<b>Soffione Shower head</b>	<b>Braccio Shower arm</b>
382/ABS.30	Ø 200 mm	300 mm
382/ABS.35	Ø 200 mm	350 mm
382/ABS.40	Ø 200 mm	400 mm



Soffione in ABS Art. 380/QABS + braccio Art. B270

ABS shower head Art. 380/QABS + shower arm Art. B270

<b>Codice Code</b>	<b>Soffione Shower head</b>	<b>Braccio Shower arm</b>
380/QABS.30	200 x 200 mm	300 mm
380/QABS.35	200 x 200 mm	350 mm
380/QABS.40	200 x 200 mm	400 mm



**Disponibile in tutte le finiture**  
**Available in all finishings**



## KIT SOFFIONE ACCIAIO + BRACCIO KIT STAINLESS STEEL SHOWER HEAD + SHOWER ARM

Soffione tondo in acciaio inox H2 mm + braccio Art. 481

Round stainless steel H2 mm shower head + shower arm Art. 481

Codice Code	Soffione Shower head	Braccio Shower arm
SB2.R20.30	Ø 200 mm	300 mm
SB2.R20.35	Ø 200 mm	350 mm
SB2.R25.30	Ø 250 mm	300 mm
SB2.R25.35	Ø 250 mm	350 mm



Soffione quadrato in acciaio inox H2 mm + braccio Art. B270

Square stainless steel H2 mm shower head + shower arm Art. B270

Codice Code	Soffione Shower head	Braccio Shower arm
SB2.Q20.30	200 x 200 mm	300 mm
SB2.Q20.35	200 x 200 mm	350 mm
SB2.Q25.30	250 x 250 mm	300 mm
SB2.Q25.35	250 x 250 mm	350 mm



Soffione tondo ISPEZIONABILE in acciaio inox H9 mm  
+ braccio Art. 481

DEMOUNTABLE round stainless steel H9 mm shower head  
+ shower arm Art. 481

Codice Code	Soffione Shower head	Braccio Shower arm
SB9.R22.30	Ø 225 mm	300 mm
SB9.R22.35	Ø 225 mm	350 mm



Soffione quadrato ISPEZIONABILE in acciaio inox H9 mm  
+ braccio Art. B270

DEMOUNTABLE square stainless steel H9 mm shower head  
+ shower arm Art. B270

Codice Code	Soffione Shower head	Braccio Shower arm
SB9.Q20.30	200x 200 mm	300 mm
SB9.Q20.35	200x 200 mm	350 mm



## KIT DOCCETTA + PRESA ACQUA + FLESSIBILE KIT HANDSHOWER + WATER CONNECTION + FLEXIBLE HOSE

### DC-50T

Doccetta in ABS Art. 01/T + presa acqua in ottone  
Art.012/T + flessibile in PVC

ABS handshower Art. 01/T + brass water  
connection Art. 012/T + PVC flexible hose



KIT-BOX

### DC-50Q

Doccetta in ABS Art. 01/Q + presa acqua in ottone  
Art. 012/Q + flessibile in PVC

ABS handshower Art. 01/Q + brass water  
connection Art. 012/Q + PVC flexible hose



KIT-BOX

### DC-40T

Doccetta in ABS Art. 01/T + presa acqua in ottone  
Art.012/T + flessibile in ottone

ABS handshower Art. 01/T + brass water  
connection Art. 012/T + brass flexible hose



KIT-BOX

### DC-40Q

Doccetta in ABS Art. 01/Q + presa acqua in ottone  
Art. 012/Q + flessibile in ottone

ABS handshower Art. 01/Q + brass water  
connection Art. 012/Q + brass flexible hose



KIT-BOX

Disponibile in tutte le finiture  
Available in all finishings

## KIT DOCCIA COMPLETO H9 COMPLETE SHOWER KIT H9

KIT doccia completo tondo, composto da soffione ISPEZIONABILE in acciaio inox H9 mm + braccio in ottone Art. 481 + presa acqua in ottone Art. 012/T + doccetta in ABS Art. 01/T + flessibile in PVC Art. 01/PVC con raccordo anti attorcigliamento

Complete round shower KIT composed by DEMOUNTABLE stainless steel shower head H9 mm + brass shower arm Art. 481 + brass water connection Art. 012/T + ABS handshower Art. 01/T + PVC flexible hose Art.01/PVC with anti-twist connection

Codice Code	Soffione Shower head	Braccio Shower arm
R22H9.30	Ø 225 mm	300 mm
R22H9.35	Ø 225 mm	350 mm



KIT doccia completo quadrato, composto da soffione ISPEZIONABILE in acciaio inox H9 mm + braccio in ottone Art. B270 + presa acqua in ottone Art. 012/Q + doccetta in ABS Art. 01/Q + flessibile in PVC Art. 01/PVC con raccordo anti attorcigliamento

Complete square shower KIT composed by DEMOUNTABLE stainless steel shower head H9 mm + brass shower arm Art. B270 + brass water connection Art. 012/Q + ABS handshower Art. 01/Q + PVC flexible hose Art.01/PVC with anti-twist connection

Codice Code	Soffione Shower head	Braccio Shower arm
Q20H9.30	200 x 200 mm	300 mm
Q20H9.35	200 x 200 mm	350 mm



## KIT DOCCIA COMPLETO H2 COMPLETE SHOWER KIT H2

KIT doccia completo tondo, composto da soffione in acciaio inox H2 mm + braccio in ottone Art. 481 + presa acqua in ottone Art. 012/T + doccetta in ABS Art. 01/T + flessibile in PVC Art. 01/PVC con raccordo anti attorcigliamento

Complete round shower KIT composed by stainless steel shower head H2 mm + brass shower arm Art. 481 + brass water connection Art. 012/T + ABS handshower Art. 01/T + PVC flexible hose Art.01/PVC with anti-twist connection

Codice Code	Soffione Shower head	Braccio Shower arm
R20H2.30	Ø 200 mm	300 mm
R20H2.35	Ø 200 mm	350 mm
R25H2.30	Ø 250 mm	300 mm
R25H2.35	Ø 250 mm	350 mm



KIT doccia completo quadrato, composto da soffione in acciaio inox H2 mm + braccio in ottone Art. B270 + presa acqua in ottone Art. 012/Q + doccetta in ABS Art. 01/Q + flessibile in PVC Art. 01/PVC con raccordo anti attorcigliamento

Complete square shower KIT composed by stainless steel shower head H2 mm + brass shower arm Art. B270 + brass water connection Art. 012/Q + ABS handshower Art. 01/Q + PVC flexible hose Art.01/PVC with anti-twist connection

Codice Code	Soffione Shower head	Braccio Shower arm
Q20H2.30	200 x 200 mm	300 mm
Q20H2.35	200 x 200 mm	350 mm
Q25H2.30	250 x 250 mm	300 mm
Q25H2.35	250 x 250 mm	350 mm



## SUPPORTI PER DOCCETTA HANDSHOWER SUPPORTS

### 02/T

Supporto fisso tondo in ottone per doccia

Round brass fixed support for handshower

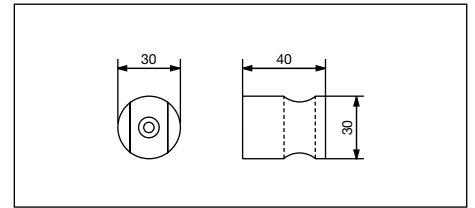

### 02/T-ABS

Supporto fisso tondo in ABS per doccia

Round ABS fixed support for handshower

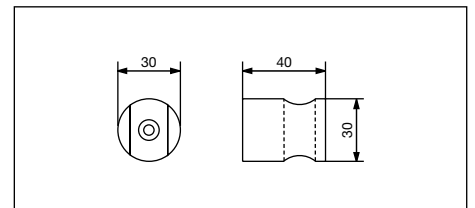

### 02/Q

Supporto fisso quadrato in ottone  
per doccia

Square brass fixed support  
for handshower

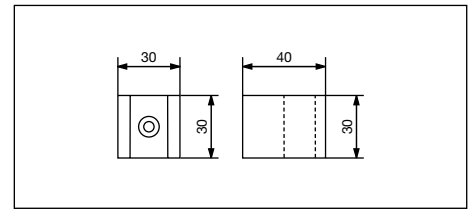

### 02/Q-ABS

Supporto fisso quadrato in ABS  
per doccia

Square ABS fixed support  
for handshower

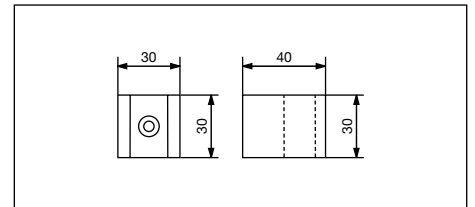

## FLESSIBILI FLEXIBLE HOSES

### 01/PVC

Tubo flessibile in PVC liscio  
L = 1500 mm con raccordo girevole anti  
attorcigliamento

Smooth PVC flexible hose L = 1500  
mm with anti-twist connection

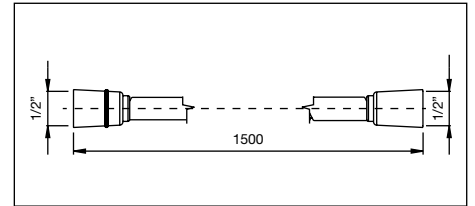

### 01/F

Tubo flessibile a doppia aggraffatura  
L = 1500 mm

Flexible hose double seam  
L = 1500 mm

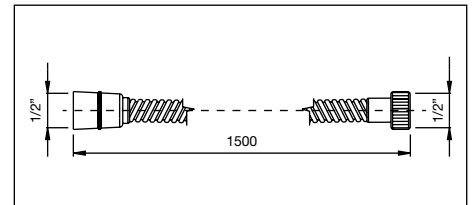

### 01/F2000

Tubo flessibile a doppia aggraffatura  
L = 2000 mm

Flexible hose double seam  
L = 2000 mm

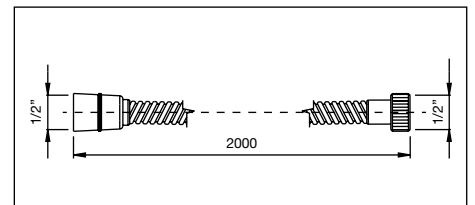

### 01/F600

Tubo flessibile a doppia aggraffatura  
L = 600 mm con due dadi da 1/2" F per  
raccordo da presa acqua  
a colonna doccia

Flexible hose double seam  
L = 600 mm with two 1/2" nuts  
for connection from water connection  
to shower column

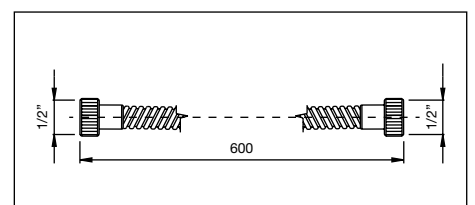

## PRESE ACQUA WATER CONNECTIONS

### 014/T

Presa acqua tonda 1/2" M x 1/2" M  
per flessibile

Round water connection 1/2" M x 1/2" M  
for flexible hose

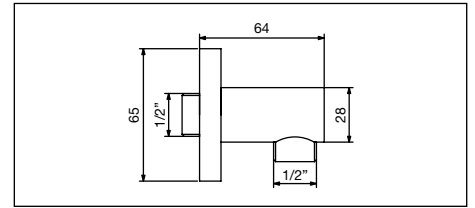

### 014/Q

Presa acqua quadrata 1/2" M x 1/2" M  
per flessibile

Square water connection 1/2" M x 1/2" M  
for flexible hose

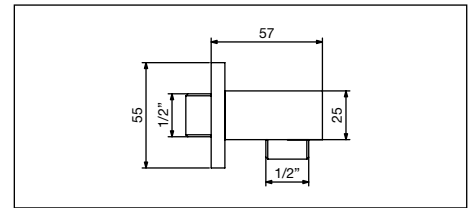

### 014/S

Presa acqua standard 1/2" M x 1/2" M  
per flessibile

Standard water connection 1/2" M x 1/2" M  
for flexible hose

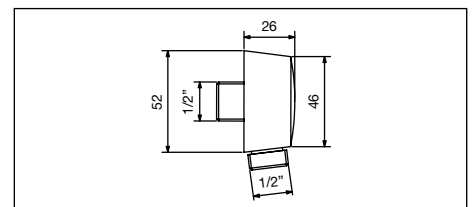

## PRESE ACQUA CON SUPPORTO WATER CONNECTIONS WITH SUPPORT

### 012/T

Pres a acqua tonda 1/2" M x 1/2" M  
con supporto per doccia

Round water connection 1/2" M x 1/2" M  
with support for handshower

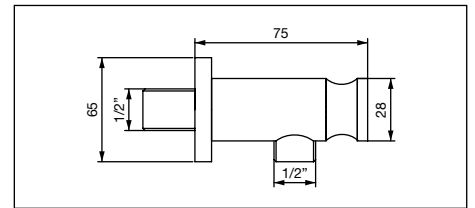

### 012/Q

Pres a acqua quadrata 1/2" M x 1/2" M  
con supporto per doccia

Square water connection 1/2" M x 1/2" M  
with support for handshower

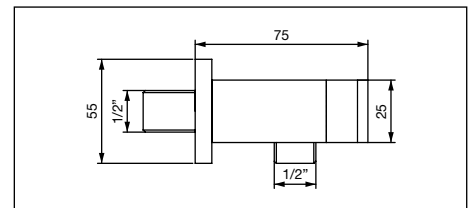

### 012/U

Pres a acqua stile antico 1/2" M x 1/2" M  
con supporto articolato per doccia

Old style water connection 1/2" M x 1/2" M  
with articulated support for handshower

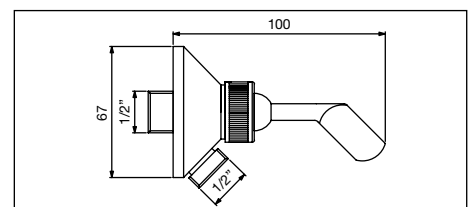



## DOCLETTE HANDSHOWERS

### 01/OLD

Doccetta stile antico in ottone  
Mod. OLD AMERICA

Brass old style handshower  
Mod. OLD AMERICA

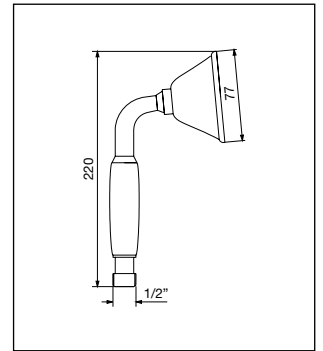

### 01/OLD CER

Doccetta stile antico in ottone  
Mod. OLD AMERICA con manico bianco

Brass old style handshower  
Mod. OLD AMERICA with white handle

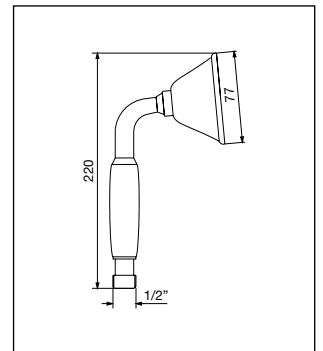

### 01/R

Doccetta stile antico in ottone  
Mod. RETRO'

Brass old style handshower  
Mod. RETRO

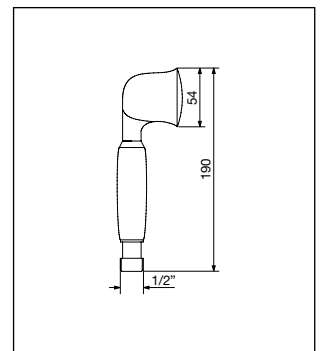

### 01/R CER

Doccetta stile antico in ottone  
Mod. RETRO' con manico bianco

Brass old style handshower  
Mod. RETRO with white handle

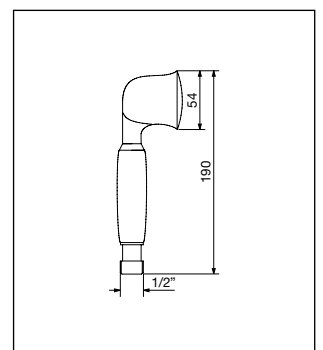

## DOCLETTE HANDSHOWERS

### 01/T

Doccetta tonda in ABS  
con sistema anticalcare

Round ABS handshower  
with antilimestone system

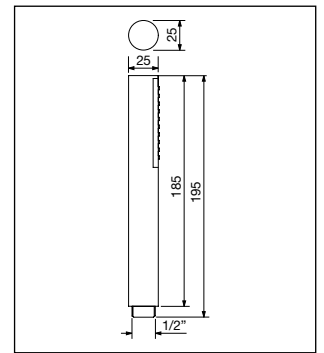

### 01/Q

Doccetta quadrata in ABS  
con sistema anticalcare

Square ABS handshower  
with antilimestone system

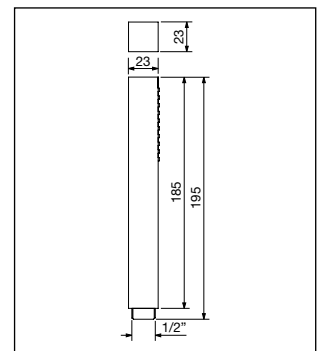

### 01/RT

Doccetta rettangolare in ottone  
con sistema anticalcare

Rectangular brass handshower  
with antilimestone system

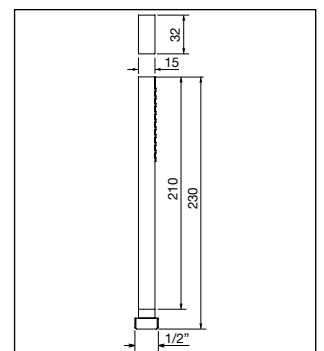

### 01/OV

Doccetta ovale in ABS  
con sistema anticalcare

Oval ABS handshower  
with antilimestone system

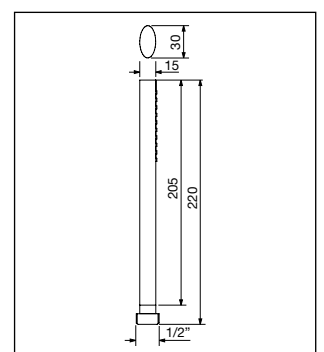

## DOCCETTE HANDSHOWERS

### 01/1G

Doccetta in ABS cromato  
con sistema anticalcare  
1 getto

Chromed ABS handshower  
with antilimestone system  
1 jet

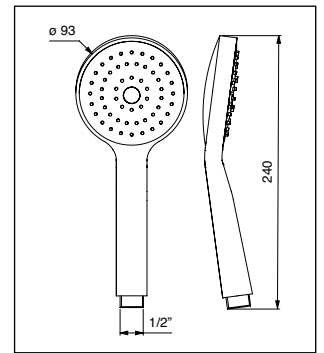

### 01/3G

Doccetta in ABS cromato  
con sistema anticalcare  
3 getti

Chromed ABS handshower  
with antilimestone system  
3 jets

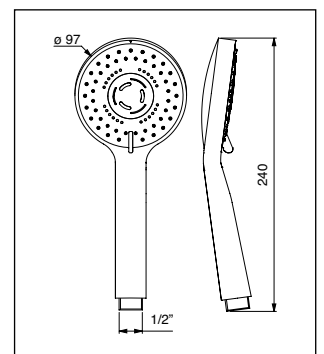

### 01/5G

Doccetta in ABS cromato  
con sistema anticalcare  
5 getti

Chromed ABS handshower  
with antilimestone system  
5 jets

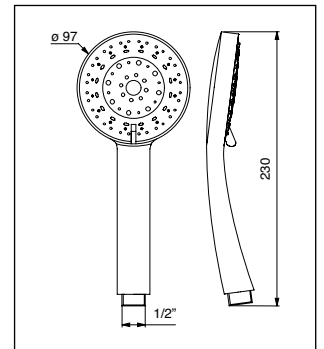

### 01/M3G

Doccetta moderna in ABS cromato  
con sistema anticalcare  
pulsante 3 getti

Modern chromed ABS handshower  
with antilimestone system  
button 3 jets

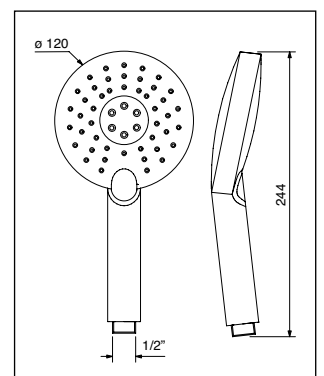



01/T



01/Q



01/OV



01/RT



01/3G



01/M3G

## SALISCENDI MINIMALISTI MINIMALIST SLIDING RAILS

### S-MA-OT

Saliscendi minimalista rotondo  
in ottone  $\varnothing$  14x600 mm  
Mod. LUSO

Minimalist brass round sliding rail  
 $\varnothing$  14x600 mm  
Mod. LUXURY

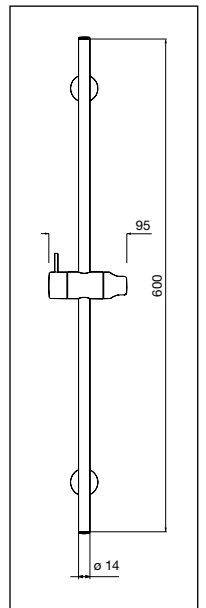

### S-MA-QOT

Saliscendi minimalista quadrato  
in ottone 14x14x600 mm  
Mod. LUSO

Minimalist brass square sliding rail  
14x14x600 mm  
Mod. LUXURY

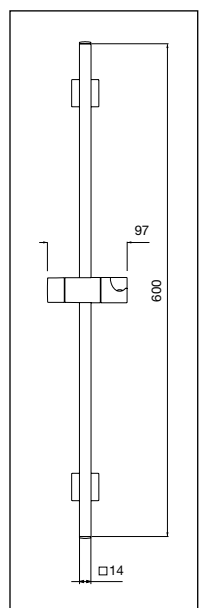

## SALISCENDI REGOLABILI ADJUSTABLE SLIDING RAILS

### S-MA-L

Saliscendi Ø 21x600 mm  
con supporti a muro regolabili  
e scorrevole con leva-stop

Sliding rail Ø 21x600 mm  
with adjustable wall-mounted supports  
and slider with leverage-stop

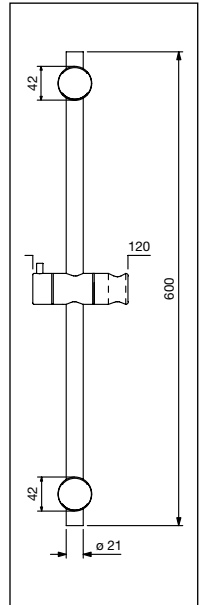

### S-MA-P

Saliscendi Ø 21x600 mm  
con supporti a muro regolabili  
e scorrevole con pulsante-stop

Sliding rail Ø 21x600 mm  
with adjustable wall-mounted supports  
and slider with button-stop

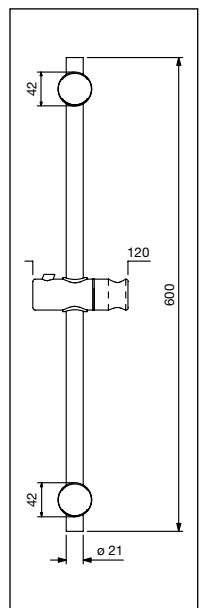





**SOFFIONI**  
Shower heads



## SOFFIONI ISPEZIONABILI IN OTTONE DEMOUNTABLE BRASS SHOWER HEADS

**379**

Soffione ispezionabile in ottone  
Ø 150 mm con snodo 1/2" F

Demountable brass shower head  
Ø 150 mm with joint 1/2" F

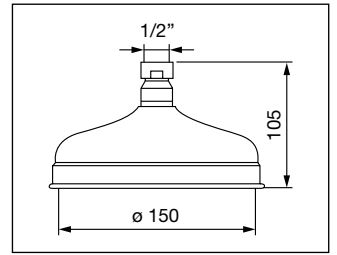

**380**

Soffione ispezionabile in ottone  
Ø 200 mm con snodo 1/2" F

Demountable brass shower head  
Ø 200 mm with joint 1/2" F

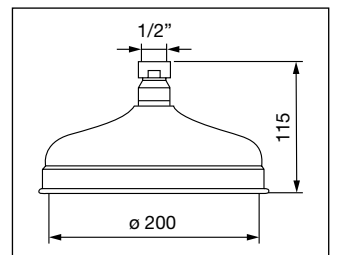

**381**

Soffione ispezionabile in ottone  
Ø 300 mm con snodo 1/2" F

Demountable brass shower head  
Ø 300 mm with joint 1/2" F

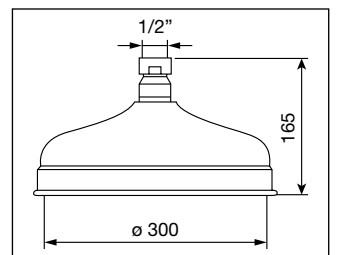

## SOFFIONI ISPEZIONABILI IN OTTONE DEMOUNTABLE BRASS SHOWER HEADS

### 379/A

Soffione ispezionabile in ottone  
Ø 150 mm  
con sistema anticalcare  
e snodo 1/2" F

Demountable brass shower head  
Ø 150 mm  
with antilimestone system  
and joint 1/2" F

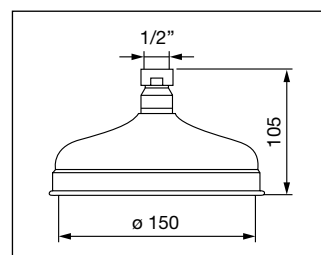

### 380/A

Soffione ispezionabile in ottone  
Ø 200 mm  
con sistema anticalcare  
e snodo 1/2" F

Demountable brass shower head  
Ø 200 mm  
with antilimestone system  
and joint 1/2" F

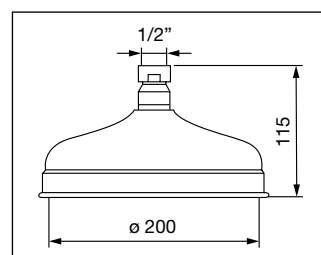

### 381/A

Soffione ispezionabile in ottone  
Ø 300 mm  
con sistema anticalcare  
e snodo 1/2" F

Demountable brass shower head  
Ø 300 mm  
with antilimestone system  
and joint 1/2" F

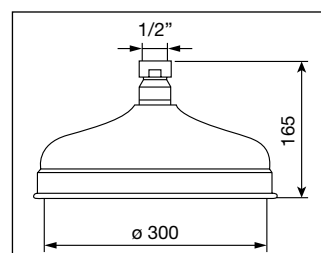

## SOFFIONI ISPEZIONABILI IN OTTONE DEMOUNTABLE BRASS SHOWER HEADS

### 382/140

Soffione minimalista ispezionabile  
in ottone Ø 140 mm  
con snodo 1/2" F

Minimalist demountable brass  
shower head Ø 140 mm  
with joint 1/2" F

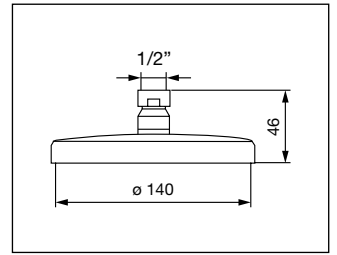

### 382/200

Soffione minimalista ispezionabile  
in ottone Ø 200 mm  
con snodo 1/2" F

Minimalist demountable brass  
shower head Ø 200 mm  
with joint 1/2" F

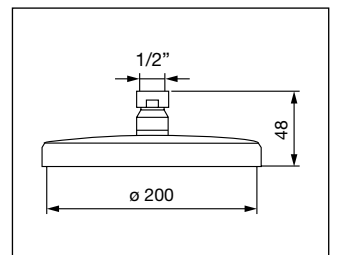

### 382/300

Soffione minimalista ispezionabile  
in ottone Ø 300 mm  
con snodo 1/2" F

Minimalist demountable brass  
shower head Ø 300 mm  
with joint 1/2" F

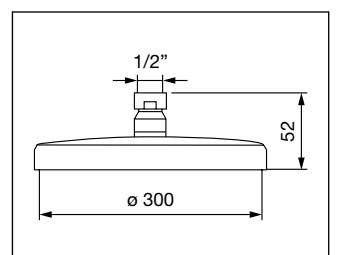

## SOFFIONI ISPEZIONABILI IN OTTONE DEMOUNTABLE BRASS SHOWER HEADS

### 382/140A

Soffione minimalista ispezionabile  
in ottone Ø 140 mm  
con sistema anticalcare  
e snodo 1/2" F

Minimalist demountable brass  
shower head Ø 140 mm  
with antilimestone system  
and joint 1/2" F

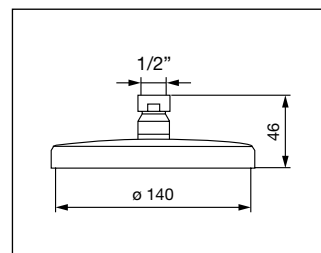

### 382/200A

Soffione minimalista ispezionabile  
in ottone Ø 200 mm  
con sistema anticalcare  
e snodo 1/2" F

Minimalist demountable brass  
shower head Ø 200 mm  
with antilimestone system  
and joint 1/2" F

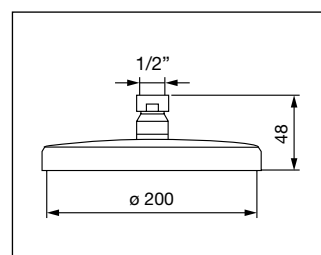

### 382/300A

Soffione minimalista ispezionabile  
in ottone Ø 300 mm  
con sistema anticalcare  
e snodo 1/2" F

Minimalist demountable brass  
shower head Ø 300 mm  
with antilimestone system  
and joint 1/2" F

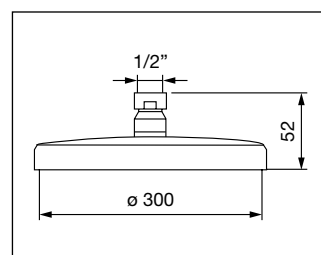

## SOFFIONI ISPEZIONABILI IN OTTONE DEMOUNTABLE BRASS SHOWER HEADS

### 383

Soffione moderno ispezionabile  
in ottone Ø 200 mm  
con snodo 1/2" F

Modern demountable brass  
shower head Ø 200 mm  
with joint 1/2" F

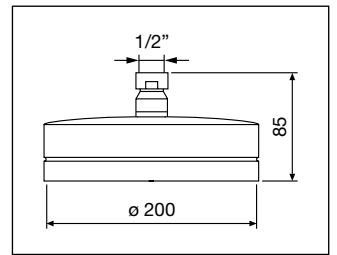

### 383/A

Soffione moderno ispezionabile  
in ottone Ø 200 mm  
con sistema anticalcare  
e snodo 1/2" F

Modern demountable brass  
shower head Ø 200 mm  
with antilimestone system  
and joint 1/2" F

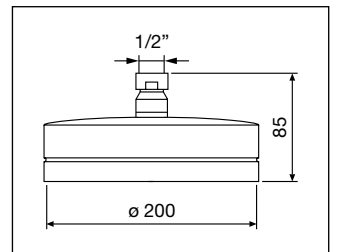

### 384

Soffione bocciardato ispezionabile  
in ottone Ø 200 mm  
con snodo 1/2" F

Brass bush hammered demountable  
shower head Ø 200 mm  
with joint 1/2" F

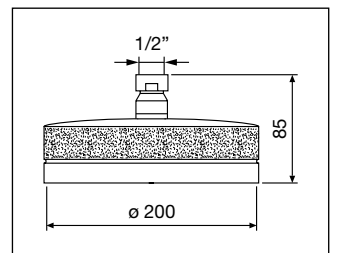

### 384/A

Soffione bocciardato ispezionabile  
in ottone Ø 200 mm  
con sistema anticalcare  
e snodo 1/2" F

Brass bush hammered demountable  
shower head Ø 200 mm  
with antilimestone system  
and joint 1/2" F

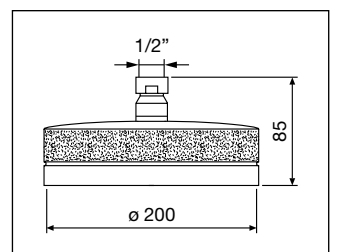

## SOFFIONI IN ABS ABS SHOWER HEADS

### 382/ABS

Soffione tondo H10 mm in ABS  
Ø 200 mm  
con sistema anticalcare  
e snodo 1/2" F

Round shower head H10 mm in ABS  
Ø 200 mm  
with antilimestone system  
and joint 1/2" F

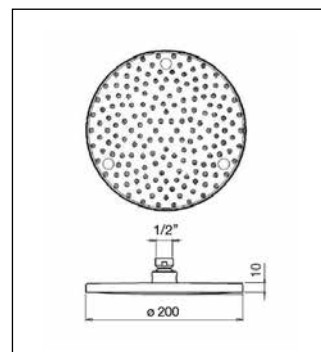

### 380/QABS

Soffione quadrato H10 mm in ABS  
200x200 mm  
con sistema anticalcare  
e snodo 1/2" F

Square shower head H10 mm in ABS  
200x200 mm  
with antilimestone system  
and joint 1/2" F

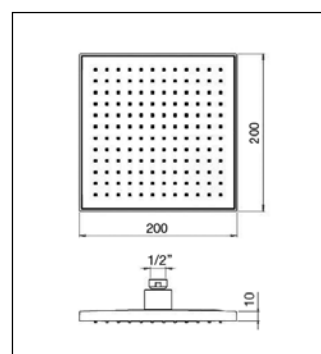

### R300OT

Soffione tondo H10 mm in ottone  
Ø 300 mm  
con sistema anticalcare  
e snodo 1/2" F

Round shower head H10 mm in brass  
Ø 300 mm  
with antilimestone system  
and joint 1/2" F

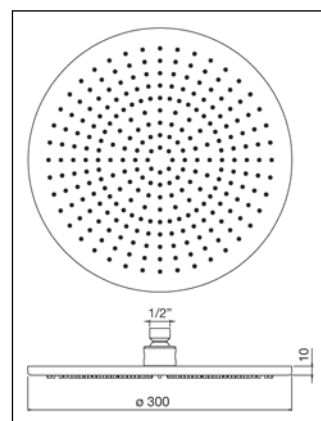

### Q300OT

Soffione quadrato H10 mm in ottone  
300x300 mm  
con sistema anticalcare  
e snodo 1/2" F

Square shower head H10 mm in brass  
300x300 mm  
with antilimestone system  
and joint 1/2" F

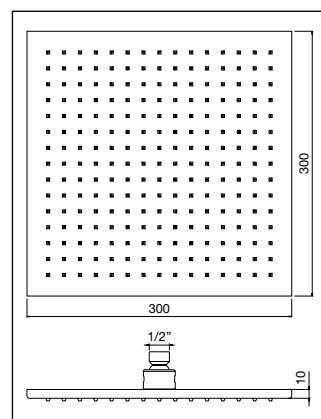

## SOFFIONI EXTRA PIATTI IN ACCIAIO INOX H2 STAINLESS STEEL EXTRA THIN SHOWER HEADS H2

### R200-H2

Soffione extra piatto in acciaio inox  
H2 mm Ø 200 mm con snodo 1/2" F,  
sistema anticalcare  
e valvola di sicurezza

Extra thin shower head in stainless steel  
H2 mm Ø 200 mm with joint 1/2" F,  
antilimestone system  
and safety valve

AISI 304

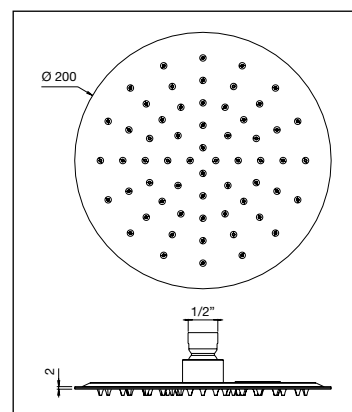

### R250-H2

Soffione extra piatto in acciaio inox  
H2 mm Ø 250 mm con snodo 1/2" F,  
sistema anticalcare  
e valvola di sicurezza

Extra thin shower head in stainless steel  
H2 mm Ø 250 mm with joint 1/2" F,  
antilimestone system  
and safety valve

AISI 304

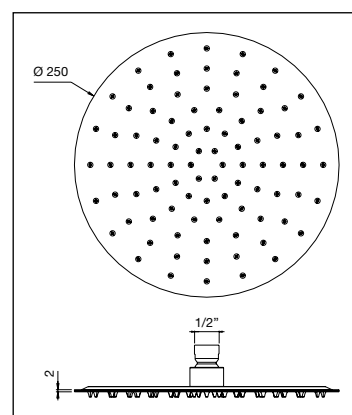

### R300-H2

Soffione extra piatto in acciaio inox  
H2 mm Ø 300 mm con snodo 1/2" F,  
sistema anticalcare  
e valvola di sicurezza

Extra thin shower head in stainless steel  
H2 mm Ø 300 mm with joint 1/2" F,  
antilimestone system  
and safety valve

AISI 304

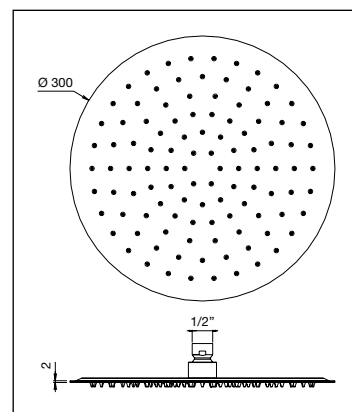

### R400-H2

Soffione extra piatto in acciaio inox  
H2 mm Ø 400 mm con snodo 1/2" F,  
sistema anticalcare  
e valvola di sicurezza

Extra thin shower head in stainless steel  
H2 mm Ø 400 mm with joint 1/2" F,  
antilimestone system  
and safety valve

AISI 304

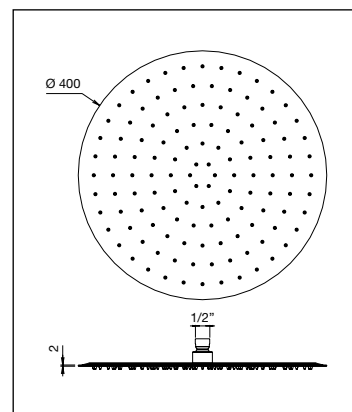

## SOFFIONI EXTRA PIATTI IN ACCIAIO INOX H2 STAINLESS STEEL EXTRA THIN SHOWER HEADS H2

### Q200-H2

Soffione extra piatto in acciaio inox H2 mm 200x200 mm con snodo 1/2" F, sistema anticalcare e valvola di sicurezza

Extra thin shower head in stainless steel H2 mm 200x200 mm with joint 1/2" F, antilimestone system and safety valve

AISI 304

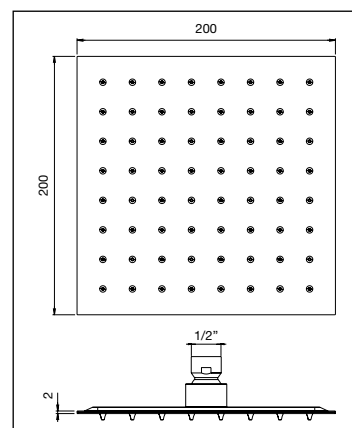

### Q250-H2

Soffione extra piatto in acciaio inox H2 mm 250x250 mm con snodo 1/2" F, sistema anticalcare e valvola di sicurezza

Extra thin shower head in stainless steel H2 mm 250x250 mm with joint 1/2" F, antilimestone system and safety valve

AISI 304

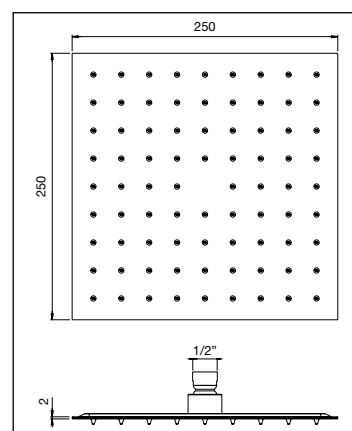

### Q300-H2

Soffione extra piatto in acciaio inox H2 mm 300x300 mm con snodo 1/2" F, sistema anticalcare e valvola di sicurezza

Extra thin shower head in stainless steel H2 mm 300x300 mm with joint 1/2" F, antilimestone system and safety valve

AISI 304

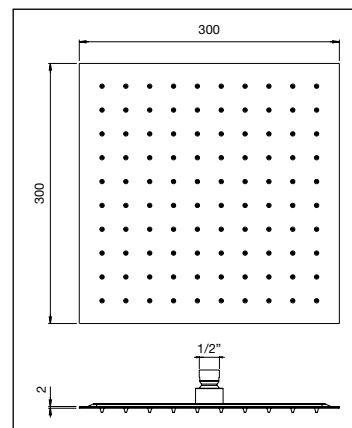

### Q400-H2

Soffione extra piatto in acciaio inox H2 mm 400x400 mm con snodo 1/2" F, sistema anticalcare e valvola di sicurezza

Extra thin shower head in stainless steel H2 mm 400x400 mm with joint 1/2" F, antilimestone system and safety valve

AISI 304

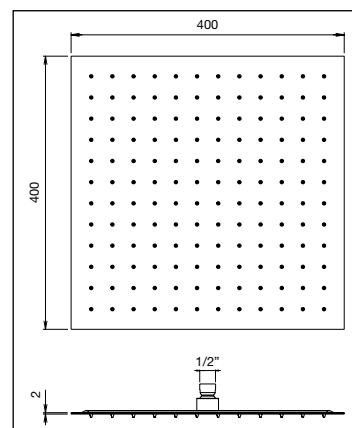



## SOFFIONI ISPEZIONABILI IN ACCIAIO INOX H9 DEMOUNTABLE STAINLESS STEEL SHOWER HEADS H9

### R225-H9

Soffione ISPEZIONABILE in acciaio  
inox H9 mm Ø 225 mm  
con snodo 1/2" F  
e sistema anticalcare

DEMOUNTABLE shower head in  
stainless steel H9 mm Ø 225 mm  
with joint 1/2" F  
and antilimestone system

AISI 304

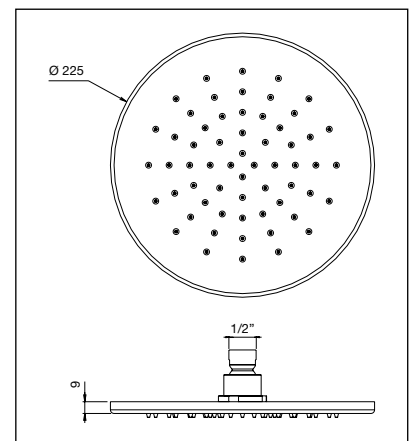

### R300-H9

Soffione ISPEZIONABILE in acciaio  
inox H9 mm Ø 300 mm  
con snodo 1/2" F  
e sistema anticalcare

DEMOUNTABLE shower head in  
stainless steel H9 mm Ø 300 mm  
with joint 1/2" F  
and antilimestone system

AISI 304

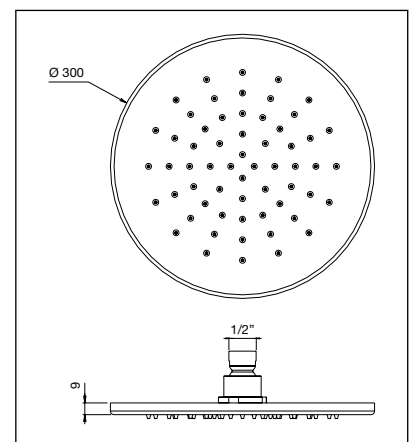

### R400-H9

Soffione ISPEZIONABILE in acciaio  
inox H9 mm Ø 400 mm  
con snodo 1/2" F  
e sistema anticalcare

DEMOUNTABLE shower head in  
stainless steel H9 mm Ø 400 mm  
with joint 1/2" F  
and antilimestone system

AISI 304

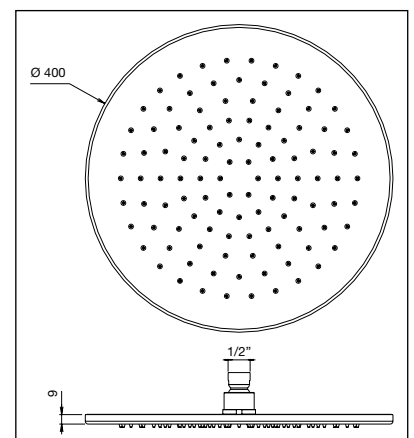

## SOFFIONI ISPEZIONABILI IN ACCIAIO INOX H9 DEMOUNTABLE STAINLESS STEEL SHOWER HEADS H9

### Q200-H9

Soffione ISPEZIONABILE in acciaio  
inox H9 mm 200x200 mm  
con snodo 1/2" F  
e sistema anticalcare

DEMOUNTABLE shower head  
in stainless steel H9 mm 200x200 mm  
with joint 1/2" F  
and antilimestone system

AISI 304

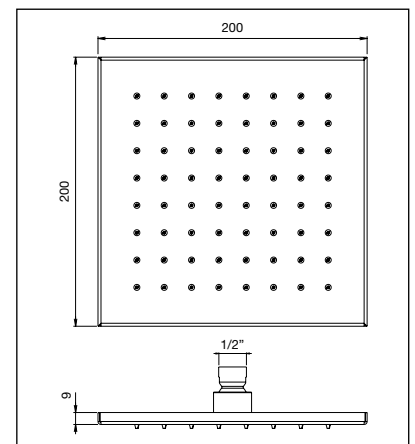

### Q300-H9

Soffione ISPEZIONABILE in acciaio  
inox H9 mm 300x300 mm  
con snodo 1/2" F  
e sistema anticalcare

DEMOUNTABLE shower head  
in stainless steel H9 mm 300x300 mm  
with joint 1/2" F  
and antilimestone system

AISI 304

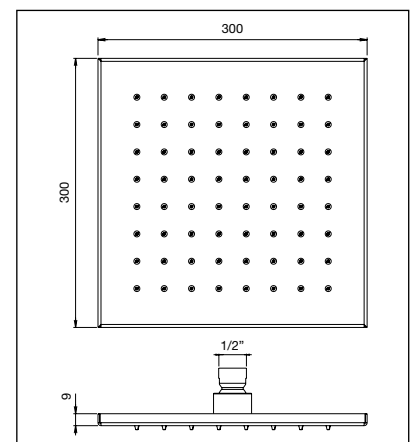

### Q400-H9

Soffione ISPEZIONABILE in acciaio  
inox H9 mm 400x400 mm  
con snodo 1/2" F  
e sistema anticalcare

DEMOUNTABLE shower head  
in stainless steel H9 mm 400x400 mm  
with joint 1/2" F  
and antilimestone system

AISI 304

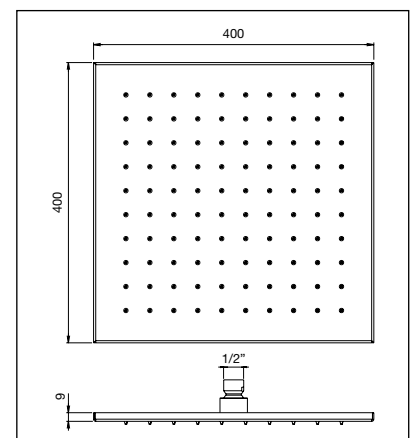

## BRACCI DOCCIA TONDI ROUND SHOWER ARMS

### 480/30

Braccio doccia tondo in ottone  
L = 300 mm con rosetta regolabile,  
attacchi 1/2" M

Brass round shower arm L = 300 mm  
with adjustable rosette,  
connections 1/2" M

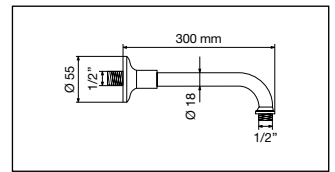

### 480/35

Braccio doccia tondo in ottone  
L = 350 mm con rosetta regolabile,  
attacchi 1/2" M

Brass round shower arm L = 350 mm  
with adjustable rosette,  
connections 1/2" M

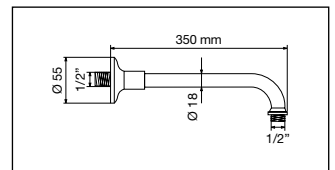

### 480/40

Braccio doccia tondo in ottone  
L = 400 mm con rosetta regolabile,  
attacchi 1/2" M

Brass round shower arm L = 400 mm  
with adjustable rosette,  
connections 1/2" M

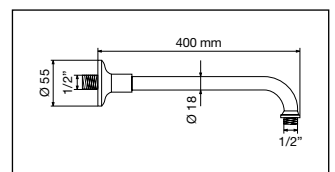

### 470/10

Braccio doccia tondo in ottone  
da soffitto L = 100 mm con rosetta  
regolabile, attacchi 1/2" M

Brass round shower arm at ceiling  
L = 100 mm with adjustable rosette,  
connections 1/2" M

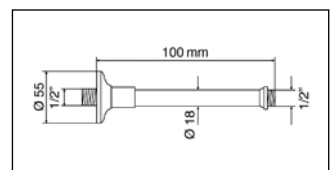

### 470/20

Braccio doccia tondo in ottone  
da soffitto L = 200 mm con rosetta  
regolabile, attacchi 1/2" M

Brass round shower arm at ceiling  
L = 200 mm with adjustable rosette,  
connections 1/2" M

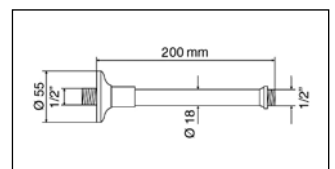

## BRACCI DOCCIA MODERNI MODERN SHOWER ARMS

### 481/30

Braccio doccia moderno in ottone  
L = 300 mm con rosetta regolabile,  
attacchi 1/2" M

Brass modern shower arm  
L = 300 mm with adjustable rosette,  
connections 1/2" M

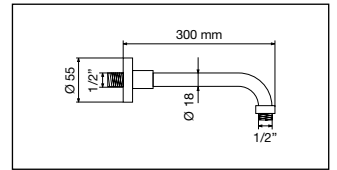

### 481/35

Braccio doccia moderno in ottone  
L = 350 mm con rosetta regolabile,  
attacchi 1/2" M

Brass modern shower arm  
L = 350 mm with adjustable rosette,  
connections 1/2" M

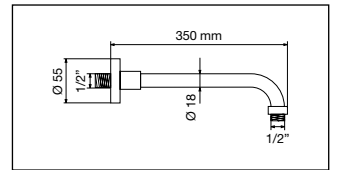

### 481/40

Braccio doccia moderno in ottone  
L = 400 mm con rosetta regolabile,  
attacchi 1/2" M

Brass modern shower arm  
L = 400 mm with adjustable rosette,  
connections 1/2" M

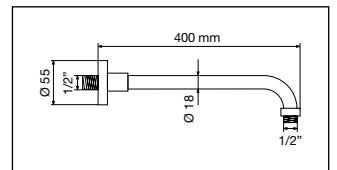

### 471/10

Braccio doccia moderno in ottone da soffitto  
L = 100 mm con rosetta regolabile,  
attacchi 1/2" M

Brass modern shower arm at ceiling  
L = 100 mm with adjustable rosette,  
connections 1/2" M

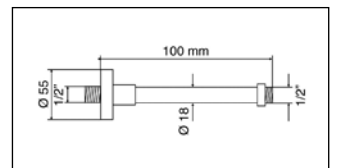

### 471/20

Braccio doccia moderno in ottone da soffitto  
L = 200 mm con rosetta regolabile,  
attacchi 1/2" M

Brass modern shower arm at ceiling  
L = 200 mm with adjustable rosette,  
connections 1/2" M

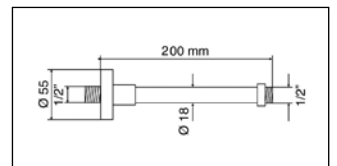

## BRACCIO DOCCIA CURVO CURVED SHOWER ARM

### 451/30

Braccio doccia curvo in ottone  
L = 300 mm con rosetta regolabile,  
attacchi 1/2" M

Brass curved shower arm  
L = 300 mm with adjustable rosette,  
connections 1/2" M

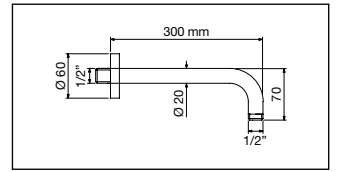

### 451/35

Braccio doccia curvo in ottone  
L = 350 mm con rosetta regolabile,  
attacchi 1/2" M

Brass curved shower arm  
L = 350 mm with adjustable rosette,  
connections 1/2" M

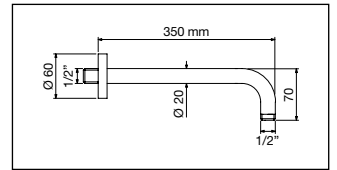

### 451/40

Braccio doccia curvo in ottone  
L = 400 mm con rosetta regolabile,  
attacchi 1/2" M

Brass curved shower arm  
L = 400 mm with adjustable rosette,  
connections 1/2" M

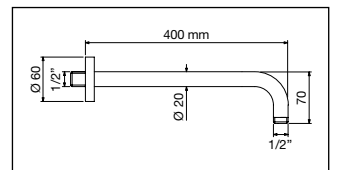

### 441/10

Braccio doccia tondo in ottone  
da soffitto L = 100 mm con rosetta  
regolabile, attacchi 1/2" M

Brass round shower arm at ceiling  
L = 100 mm with adjustable rosette,  
connections 1/2" M

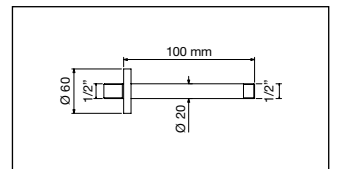

### 441/20

Braccio doccia tondo in ottone  
da soffitto L = 200 mm con rosetta  
regolabile, attacchi 1/2" M

Brass round shower arm at ceiling  
L = 200 mm with adjustable rosette,  
connections 1/2" M

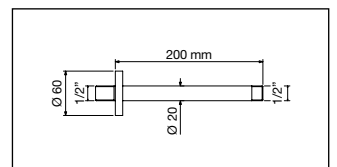

## BRACCIO DOCCIA TONDO MINIMALE MINIMALIST ROUND SHOWER ARM

### 461/30

Braccio doccia tondo minimale  
in ottone L = 300 mm Mod. LUSSO,  
con rosetta e attacchi 1/2" M

Brass minimalist round shower arm  
L = 300 mm Mod. LUXURY,  
with rosette and connections 1/2" M

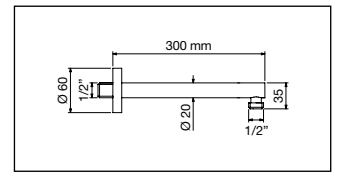

### 461/35

Braccio doccia tondo minimale  
in ottone L = 350 mm Mod. LUSSO,  
con rosetta e attacchi 1/2" M

Brass minimalist round shower arm  
L = 350 mm Mod. LUXURY,  
with rosette and connections 1/2" M

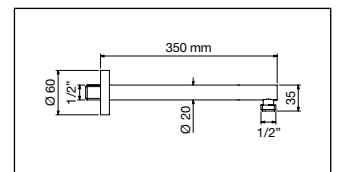

### 461/40

Braccio doccia tondo minimale  
in ottone L = 400 mm Mod. LUSSO,  
con rosetta e attacchi 1/2" M

Brass minimalist round shower arm  
L = 400 mm Mod. LUXURY,  
with rosette and connections 1/2" M

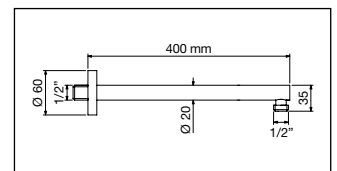

## BRACCI DOCCIA QUADRATI SQUARE SHOWER ARMS

### B270/30

Braccio doccia quadrato in ottone  
L = 300 mm con rosetta regolabile,  
attacchi 1/2" M

Brass square shower arm L = 300 mm  
with adjustable rosette,  
connections 1/2" M

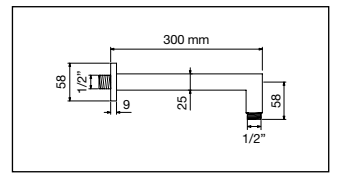

### B270/35

Braccio doccia quadrato in ottone  
L = 350 mm con rosetta regolabile,  
attacchi 1/2" M

Brass square shower arm L = 350 mm  
with adjustable rosette,  
connections 1/2" M

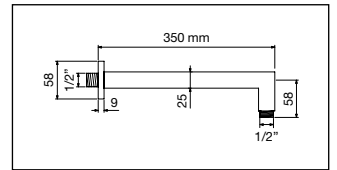

### B270/40

Braccio doccia quadrato in ottone  
L = 400 mm con rosetta regolabile,  
attacchi 1/2" M

Brass square shower arm L = 400 mm  
with adjustable rosette,  
connections 1/2" M

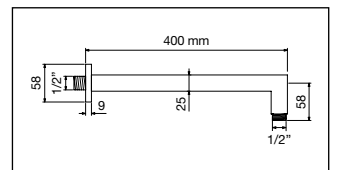

## BRACCI DOCCIA QUADRATI MINIMALI MINIMALIST SQUARE SHOWER ARMS

### 280/QOT30

Braccio doccia quadrato minimale  
in ottone L = 300 mm Mod. LUSO,  
con rosetta e attacchi 1/2" M

Brass minimalist square shower arm  
L = 300 mm Mod. LUXURY, with rosette  
and connections 1/2" M

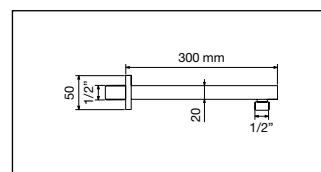

### 280/QOT35

Braccio doccia quadrato minimale  
in ottone L = 350 mm Mod. LUSO,  
con rosetta e attacchi 1/2" M

Brass minimalist square shower arm  
L = 350 mm Mod. LUXURY, with rosette  
and connections 1/2" M

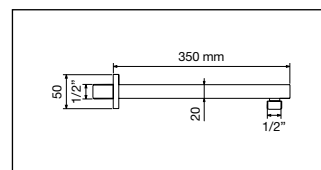

### 280/QOT40

Braccio doccia quadrato minimale  
in ottone L = 400 mm Mod. LUSO,  
con rosetta e attacchi 1/2" M

Brass minimalist square shower arm  
L = 400 mm Mod. LUXURY, with rosette  
and connections 1/2" M

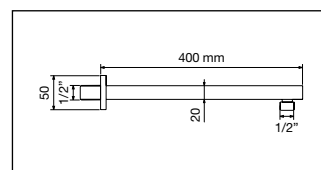

### 290/10

Braccio doccia quadrato minimale  
in ottone da soffitto L = 100 mm  
Mod. LUSO, con rosetta e attacchi 1/2" M

Brass minimalist square shower arm  
at ceiling L = 100 mm Mod. LUXURY,  
with rosette and connections 1/2" M

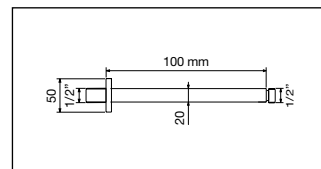

### 290/20

Braccio doccia quadrato minimale  
in ottone da soffitto L = 200 mm  
Mod. LUSO, con rosetta e attacchi 1/2" M

Brass minimalist square shower arm  
at ceiling L = 200 mm Mod. LUXURY,  
with rosette and connections 1/2" M

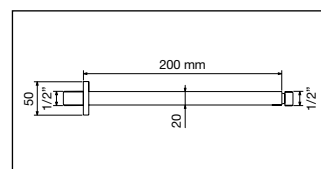



## BRACCI DOCCIA ALTI HIGH SHOWER ARMS

### 482

Braccio doccia alto in ottone  
Mod. STANDARD con rosetta  
regolabile e attacchi 1/2" M

High shower arm in brass  
Mod. STANDARD with adjustable  
rosette and connections 1/2" M

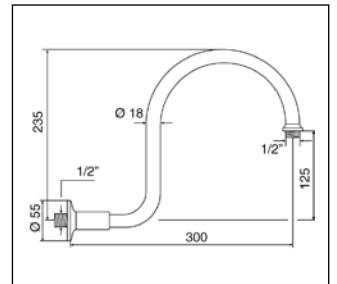

### 483

Braccio doccia alto in ottone  
Mod. A PONTE con rosetta regolabile  
e attacchi 1/2" M

High shower arm in brass  
Mod. BRIDGE with adjustable rosette  
and connections 1/2" M

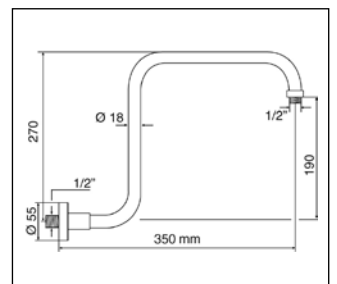
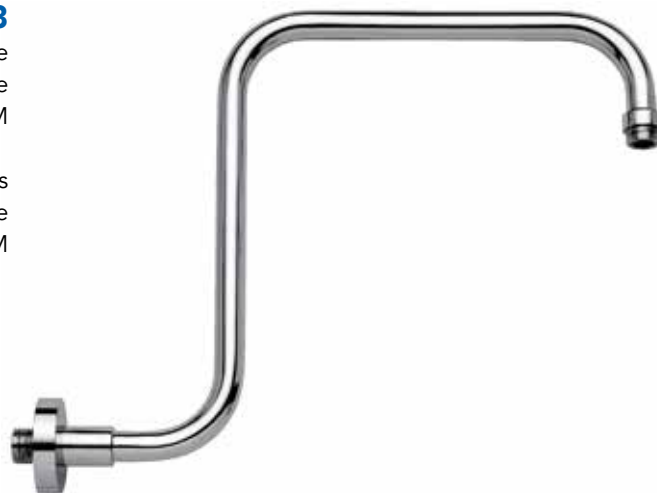

## BRACCI DOCCIA SPECIALI SPECIAL SHOWER ARMS

### BGR/1035

Braccio doccia orientabile  
H = 100 mm x L = 350 mm  
con attacchi 1/2" M

Swivel shower arm  
H = 100 x L = 350 mm  
with connections 1/2" M

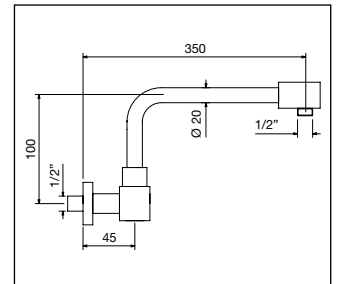

**Produzione SU MISURA  
a richiesta  
Tailor-made on request**

### 484/35

Braccio doccia rialzato  
L = 350 mm  
con attacchi 1/2" M

Raised shower arm  
L = 350 mm  
with connections 1/2" M

### 484/30

L = 300 mm

### 484/40

L = 400 mm

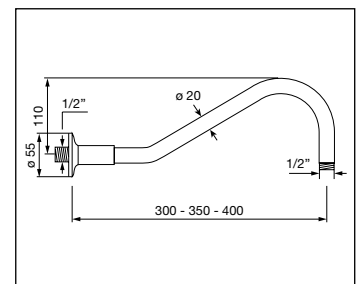

## BRACCI DOCCIA ECONOMICI E LEGGERI ECONOMIC AND LIGHT SHOWER ARMS

### 280/30

Braccio doccia tondo economico e leggero in ottone L = 300 mm con rosetta e attacchi 1/2" M

Economic and light brass round shower arm L = 300 mm with rosette and connections 1/2" M

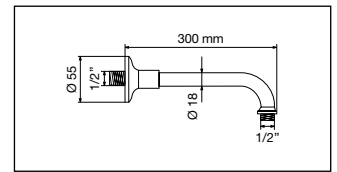

### 280/35

Braccio doccia tondo economico e leggero in ottone L = 350 mm con rosetta e attacchi 1/2" M

Economic and light brass round shower arm L = 350 mm with rosette and connections 1/2" M

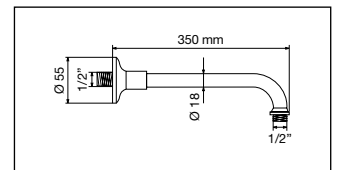

### 280/40

Braccio doccia tondo economico e leggero in ottone L = 400 mm con rosetta e attacchi 1/2" M

Economic and light brass round shower arm L = 400 mm with rosette and connections 1/2" M

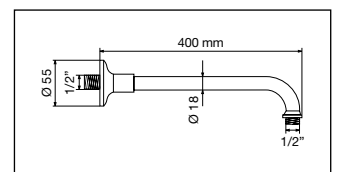

### 280/DR10

Braccio doccia tondo economico e leggero in ottone da soffitto L = 100 mm con rosetta e attacchi 1/2" M

Economic and light brass round shower arm at ceiling L = 100 mm with rosette and connections 1/2" M

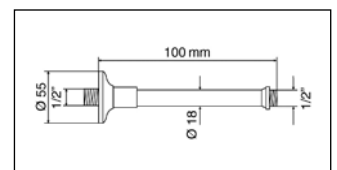

### 280/DR20

Braccio doccia tondo economico e leggero in ottone da soffitto L = 200 mm con rosetta e attacchi 1/2" M

Economic and light brass round shower arm at ceiling L = 200 mm with rosette and connections 1/2" M

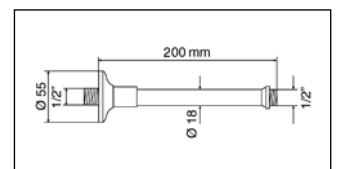



WELLNESS

## PANNELLO DOCCIA PER RISTRUTTURAZIONE SHOWER PANEL FOR RESTRUCTURATION

### CLD-ME

Pannello doccia in acciaio inox con spessore pannello 30 mm, deviatore a due vie con miscelatore monocomando, soffione extra piatto solo pioggia con valvola di sicurezza, flessibile PVC argento e presa acqua con supporto per doccetta

Shower panel in stainless steel with panel 30 mm thickness, two ways diverter with single-lever mixer, extra-fine shower head only rain with safety valve, flexible hose in silver PVC and water connection with support for handshower

### CLD-TM

Pannello doccia in acciaio inox con spessore pannello 30 mm, deviatore a due vie con miscelatore termostatico, soffione extra piatto solo pioggia con valvola di sicurezza, flessibile PVC argento e presa acqua con supporto per doccetta

Shower panel in stainless steel with panel 30 mm thickness, two ways diverter with thermostatic mixer, extra-fine shower head only rain with safety valve, flexible hose in silver PVC and water connection with support for handshower

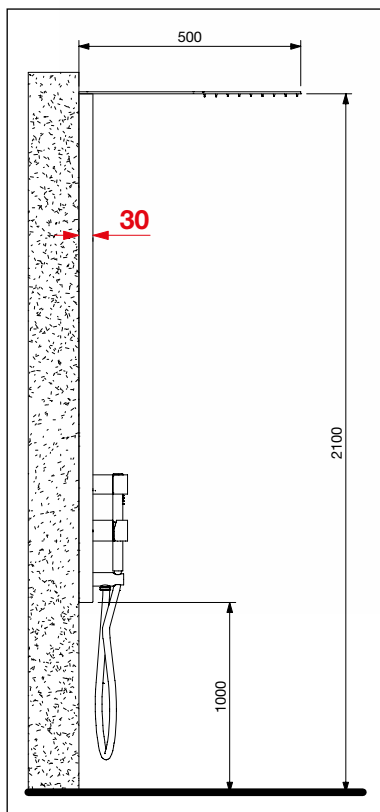
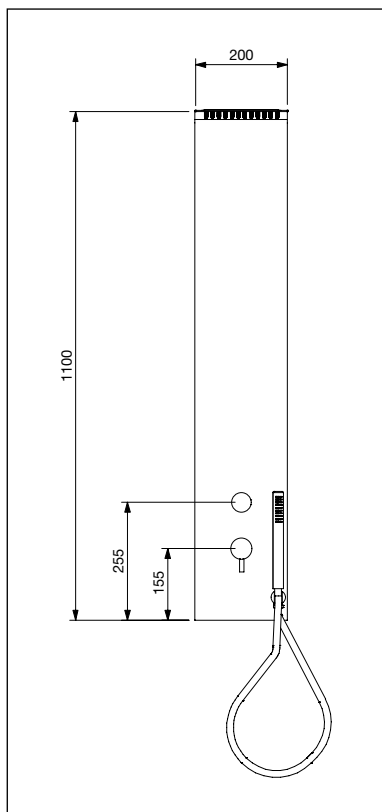

**Produzione SU MISURA  
a richiesta  
Tailor-made on request**

### INFORMAZIONI TECNICHE

Le dimensioni esterne, lo spessore contenuto di 30 mm e la facilità di montaggio con sistema "easy-locking" ne fanno un prodotto ideale anche per le ristrutturazioni

- Pannello doccia e soffione in acciaio AISI 304
- Rubinetteria completamente in ottone
- Ugelli anticalcare in silicone

### TECHNICAL DETAILS

External dimensions, reduced thickness 30 mm and the easy installation with "easy-locking" system make this product the perfect solution also for all restructuration works

- Shower panel and shower head in AISI 304 stainless steel
- All taps totally in brass
- Antilimestone nozzles in silicon

## PANNELLO DOCCIA A INCASSO CON TELAIO 30 mm - ELEGANT BUILT-IN SHOWER PANEL WITH 30 mm FRAME - ELEGANT

### EL-ME

Pannello doccia Mod. ELEGANT in acciaio inox con telaio a incasso da 30 mm di spessore, deviatore a tre vie con miscelatore monocomando, soffione solo pioggia, due getti frontali, flessibile PVC argento e presa acqua con supporto per doccetta

Shower panel Mod. ELEGANT in stainless steel with built-in frame in 30 mm thickness, three ways diverter with single-lever mixer, extra-fine shower head only rain, two frontal body jets, flexible hose in silver PVC and water connection with support for handshower

### EL-TM

Pannello doccia Mod. ELEGANT in acciaio inox con telaio a incasso da 30 mm, deviatore a tre vie con miscelatore termostatico, soffione solo pioggia, due body jet frontali, flessibile PVC argento e presa acqua con supporto per doccetta

Shower panel Mod. ELEGANT in stainless steel with built-in frame in 30 mm thickness, three ways diverter with thermostatic mixer, extra-fine shower head only rain, two frontal body jets, flexible hose in silver PVC and water connection with support for handshower

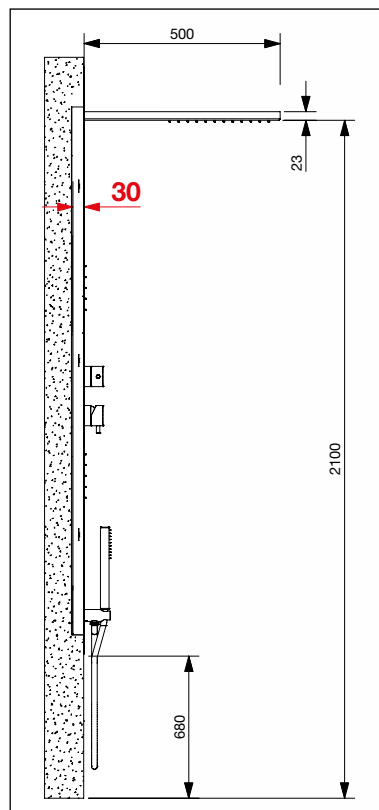
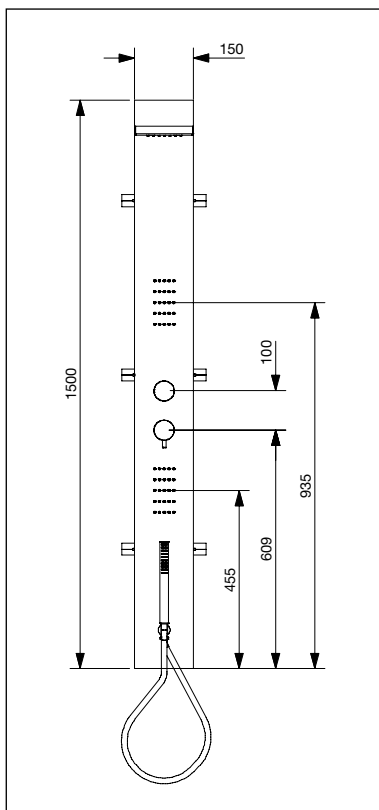
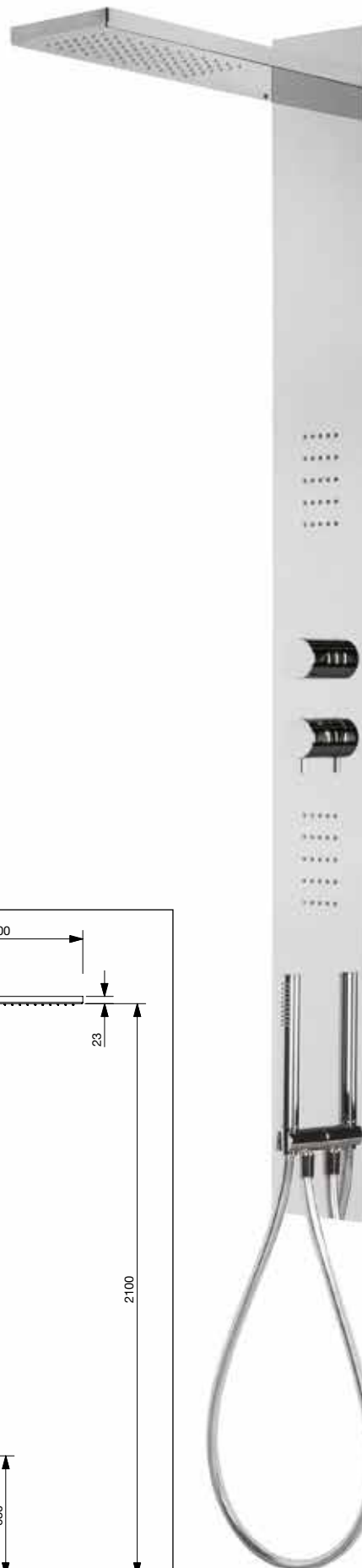

### INFORMAZIONI TECNICHE

Le dimensioni esterne, lo spessore contenuto di 30 mm del telaio ad incasso e la facilità di montaggio ne fanno un prodotto ideale anche per le ristrutturazioni

- Pannello doccia con getti frontali e soffione in acciaio AISI 304
- Rubinetteria completamente in ottone
- Ugelli anticalcare in silicone

### TECHNICAL DETAILS

External dimensions, reduced thickness 30 mm of built-in frame and the easy installation make this product the perfect solution also for all restructuration works

- Shower panel and shower head in AISI 304 stainless steel
- All taps totally in brass
- Antilimestone nozzles in silicon



## SERIE WELLNESS - A PARETE WELLNESS SERIE - WALL MOUNTED

### V11M

Soffione a parete serie WELLNESS,  
in acciaio inox, stondato,  
1 getto solo pioggia

Wall mounted rounded shower head  
WELLNESS serie in stainless steel,  
1 jet rain

AISI 304

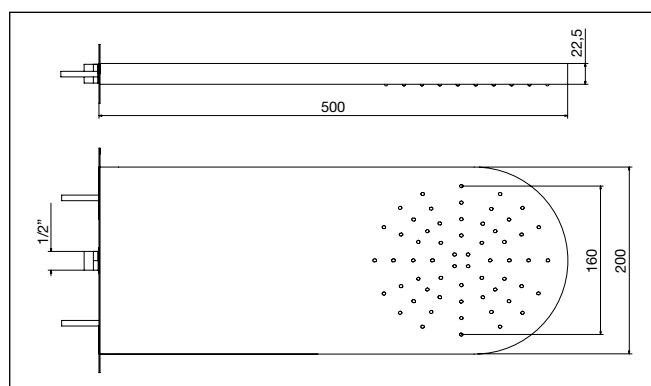
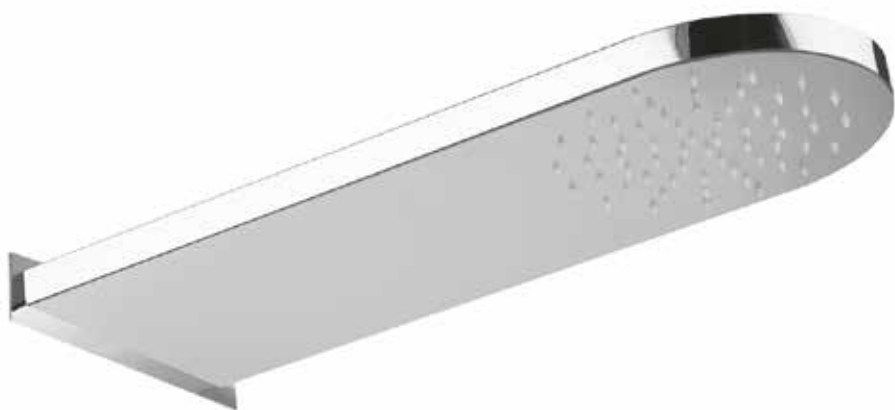

### V12M

Soffione a parete serie WELLNESS,  
in acciaio inox, stondato,  
2 getti pioggia/cascata

Wall mounted rounded shower head  
WELLNESS serie in stainless steel,  
2 jets rain/cascade

AISI 304

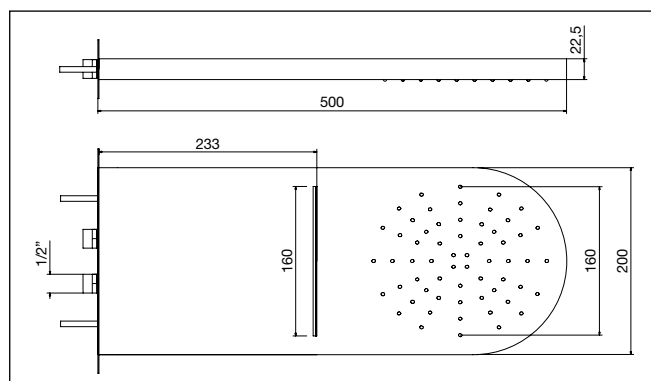
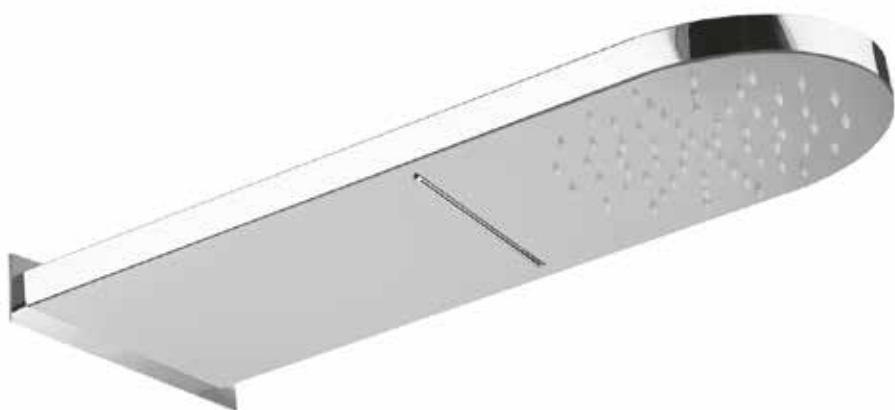

**Per predisposizione  
impianto idrico richiedere  
scheda tecnica**

**For water system set-up  
ask for installation manual**



## SERIE WELLNESS - A PARETE WELLNESS SERIE - WALL MOUNTED

### V21M

Soffione a parete serie WELLNESS  
in acciaio inox, 1 getto solo pioggia

Wall mounted shower head  
WELLNESS serie in stainless steel,  
1 jet rain

AISI 304

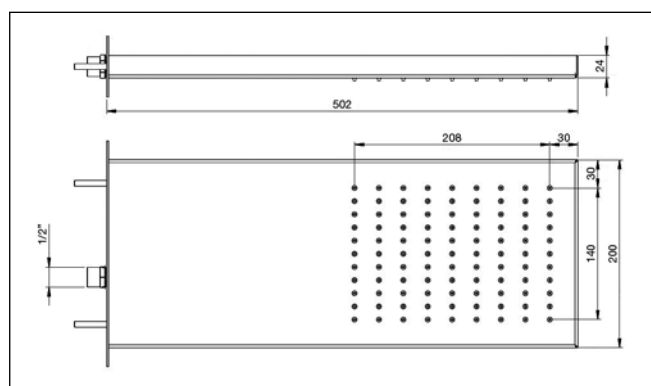

### V22M

Soffione a parete serie WELLNESS  
in acciaio inox, 2 getti pioggia/cascata

Wall mounted shower head  
WELLNESS serie in stainless steel,  
2 jets rain/cascade

AISI 304

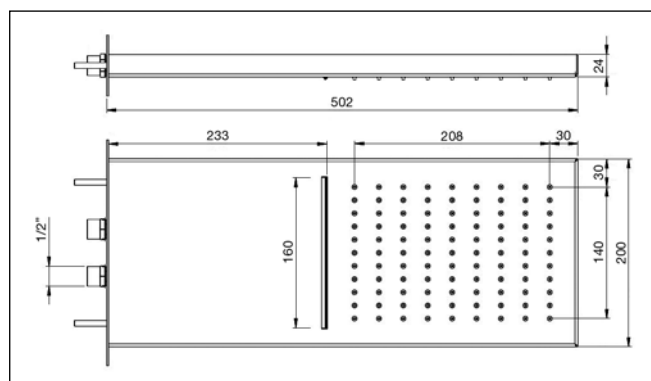

**Per predisposizione  
impianto idrico richiedere  
scheda tecnica**

**For water system set-up  
ask for installation manual**

## SERIE WELLNESS - EXTRA PIATTO - A PARETE WELLNESS SERIE - EXTRA THIN - WALL MOUNTED

### V31M

Soffione a parete extra piatto  
in acciaio inox serie WELLNESS,  
1 getto solo pioggia  
con valvola di sicurezza

GLOSSY or BRUSHED  
Extra thin wall mounted shower head  
in stainless steel WELLNESS serie,  
1 jet rain with safety valve

AISI 304

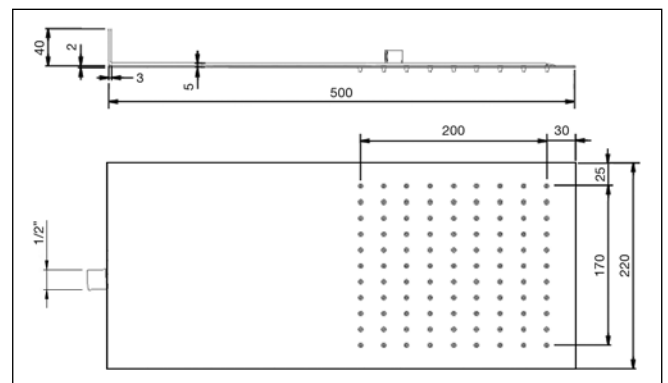

### V32M

Soffione a parete extra piatto  
in acciaio inox serie WELLNESS,  
2 getti pioggia/cascata  
con valvola di sicurezza

Extra thin wall mounted shower head  
in stainless steel WELLNESS serie,  
2 jets rain/cascade with safety valve

AISI 304

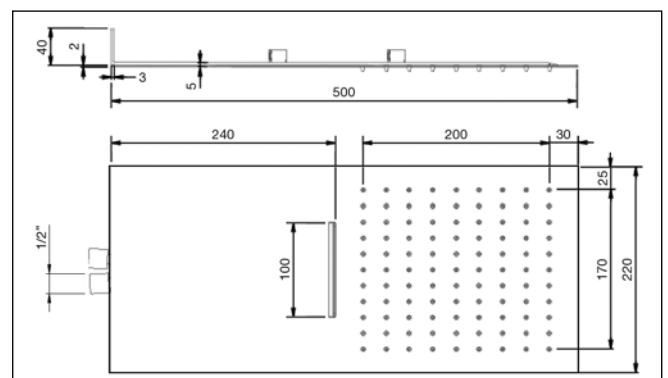

**Per predisposizione  
impianto idrico richiedere  
scheda tecnica**

**For water system set-up  
ask for installation manual**

## SERIE WELLNESS - EXTRA PIATTO - A PARETE WELLNESS SERIE - EXTRA THIN - WALL MOUNTED

### V33M

Soffione a parete extra piatto  
in acciaio inox serie WELLNESS,  
1 getto solo pioggia  
con valvola di sicurezza

Extra thin wall mounted shower head  
in stainless steel WELLNESS serie,  
1 jet rain with safety valve

AISI 304

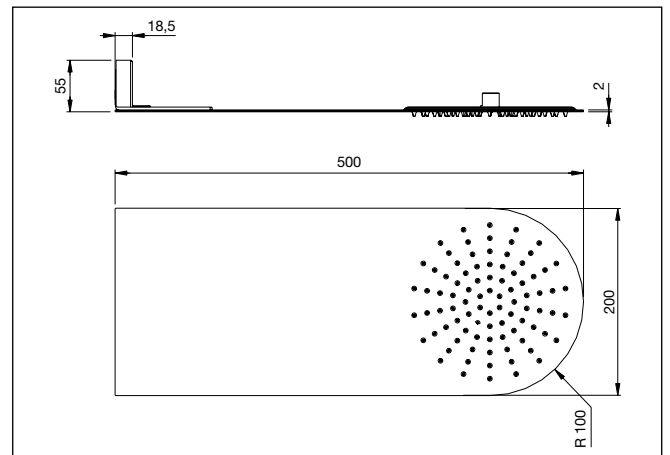

### V34M

Soffione a parete extra piatto  
in acciaio inox serie WELLNESS,  
2 getti pioggia/cascata  
con valvola di sicurezza

Extra thin wall mounted shower head  
in stainless steel WELLNESS serie,  
2 jets rain/cascade with safety valve

AISI 304

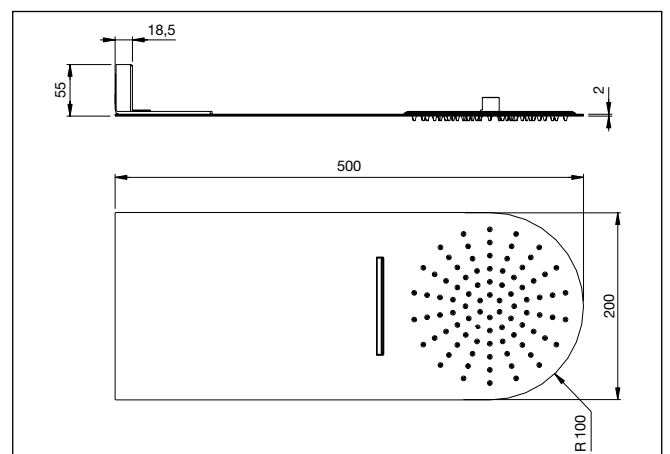

**Per predisposizione  
impianto idrico richiedere  
scheda tecnica**

**For water system set-up  
ask for installation manual**

# SERIE WELLNESS - EXTRA PIATTO - A PARETE WELLNESS SERIE - EXTRA THIN - WALL MOUNTED

## V35M

Soffione a parete extra piatto  
in acciaio inox serie WELLNESS,  
1 getto solo pioggia  
con valvola di sicurezza

Extra thin wall mounted shower head  
in stainless steel WELLNESS serie,  
1 jet rain with safety valve

AISI 304

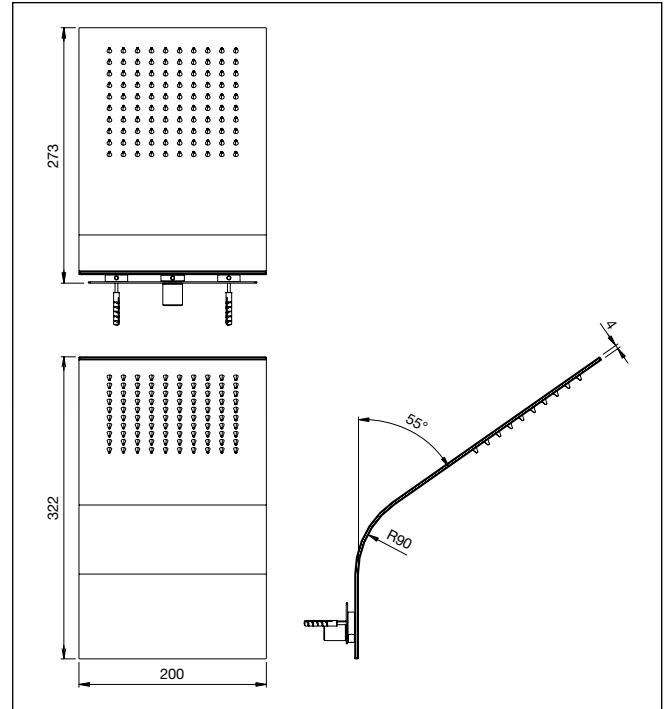
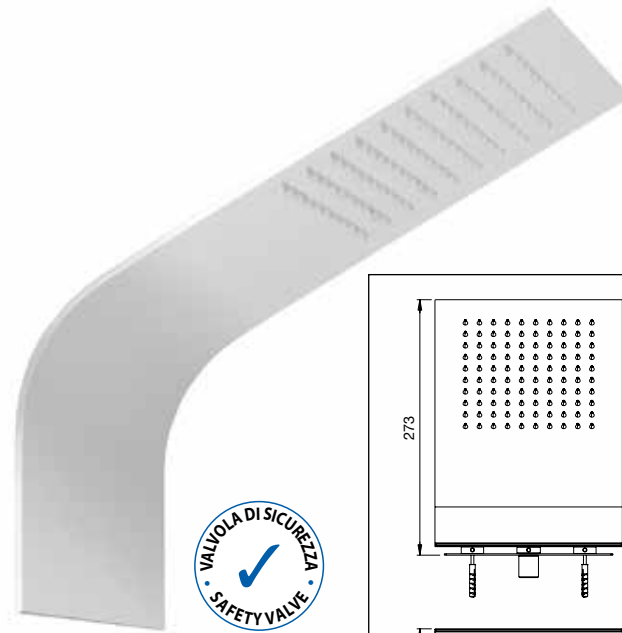

## V36M

Soffione a parete extra piatto  
in acciaio inox serie WELLNESS,  
1 getto solo pioggia  
con valvola di sicurezza

Extra thin wall mounted shower head  
in stainless steel WELLNESS serie,  
1 jet rain with safety valve

AISI 304

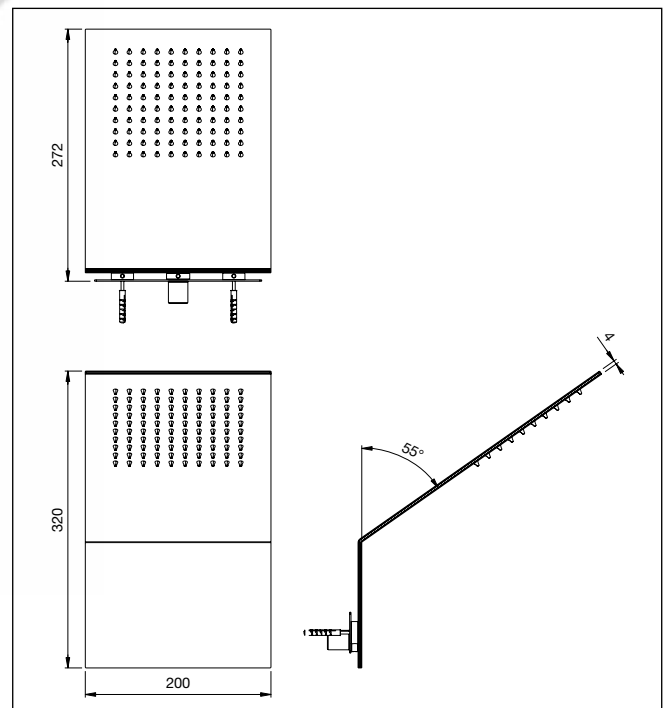
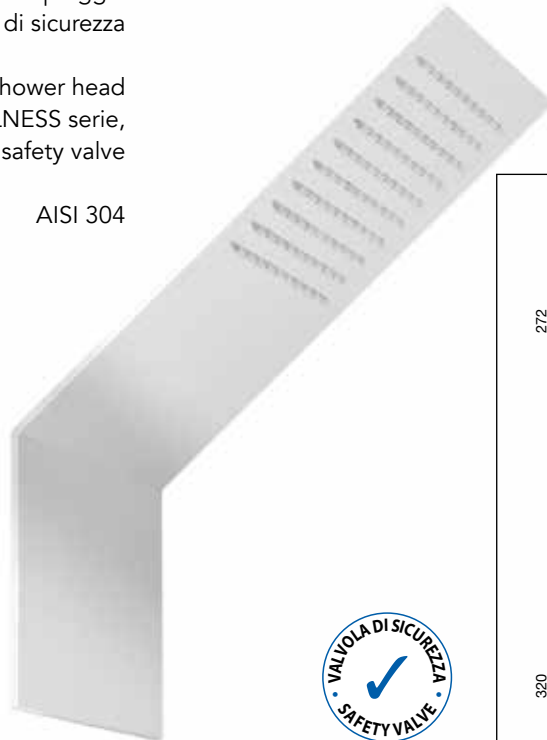



## SERIE WELLNESS - HARMONY WELLNESS SERIE - HARMONY

### V81M

Soffione di design a parete in acciaio inox,  
Mod. HARMONY - Tondo

Wall mounted design shower head  
in stainless steel, Mod. HARMONY - Round

AISI 304

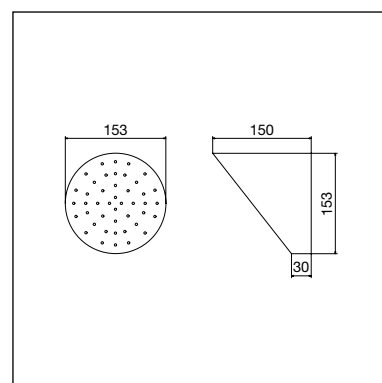

### V82M

Soffione di design a parete in acciaio inox,  
Mod. HARMONY - Quadrato

Wall mounted design shower head  
in stainless steel, Mod. HARMONY - Square

AISI 304

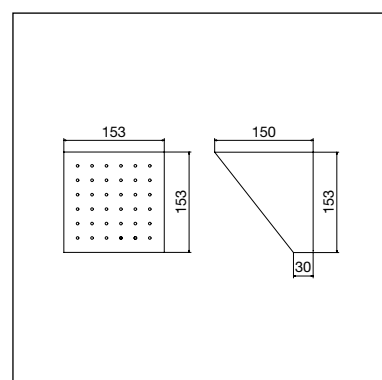

**Per predisposizione  
impianto idrico richiedere  
scheda tecnica**

**For water system set-up  
ask for installation manual**



## SERIE WELLNESS - CASCADE MODERNE WELLNESS SERIE - MODERN CASCADES

### V41M

Cascata moderna extra piatta a parete  
in acciaio inox  
Mod. TONDO

Extra thin modern wall mounted  
cascade in stainless steel  
Mod. ROUND

AISI 304

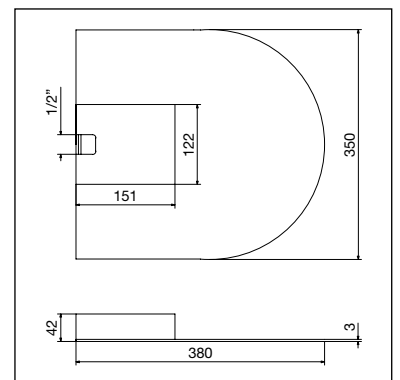
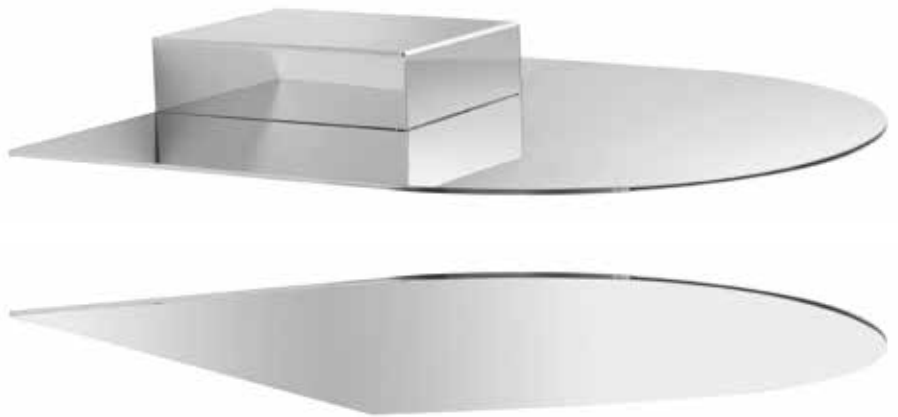

### V42M

Cascata moderna extra piatta a parete  
in acciaio inox  
Mod. QUADRATO

Extra thin modern wall mounted  
cascade in stainless steel  
Mod. SQUARE

AISI 304

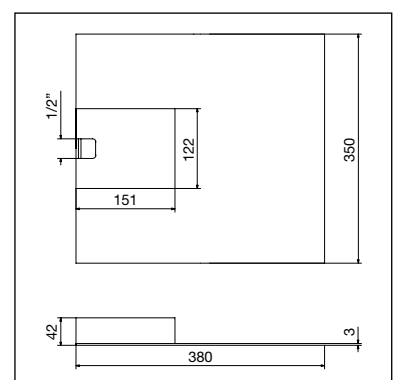
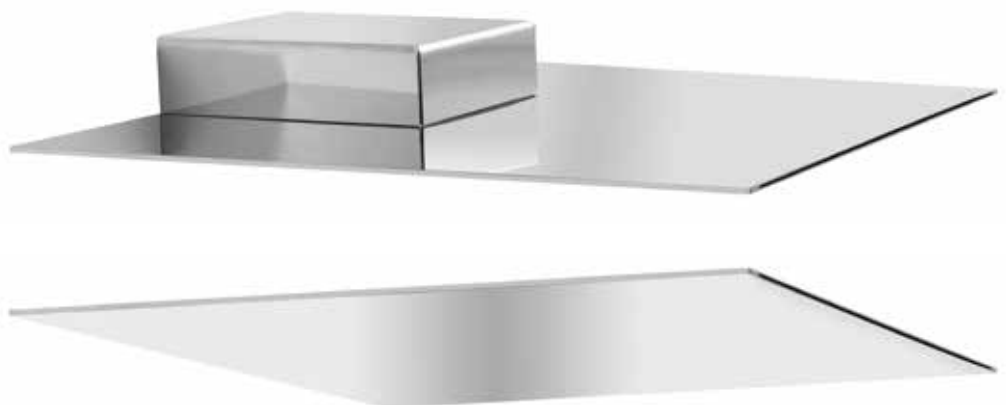

**Per predisposizione  
impianto idrico richiedere  
scheda tecnica**

**For water system set-up  
ask for installation manual**





## SERIE WELLNESS - CASCADE RELAX WELLNESS SERIE - RELAX CASCADES

### V43M

Cascata extra piatta a parete  
in acciaio inox  
Mod. RELAX

Extra thin wall mounted cascade  
in stainless steel  
Mod. RELAX

AISI 304

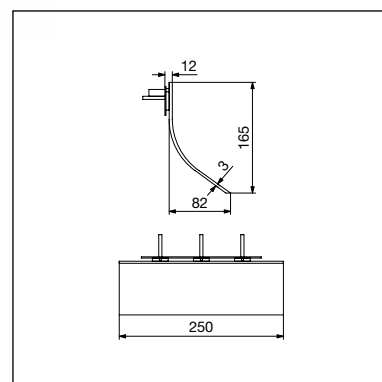

### V44M

Cascata a vista extra piatta a parete  
in acciaio inox  
Mod. TOP RELAX

Extra thin wall mounted cascade  
at sight in stainless steel  
Mod. TOP RELAX

AISI 304

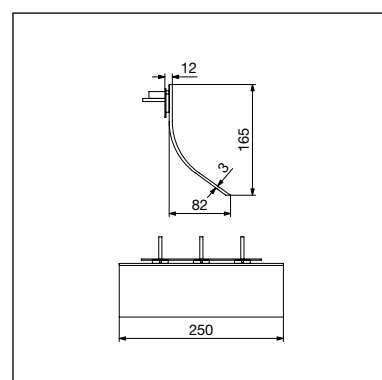

**Per predisposizione  
impianto idrico richiedere  
scheda tecnica**

**For water system set-up  
ask for installation manual**



## BOCCHE - SECRET SPOUTS - SECRET

### CS11M

Bocca incasso a parete in acciaio inox,  
Mod. SECRET con placca tonda

Built-in wall mounted spout in stainless  
steel, Mod. SECRET with round rosette

AISI 304

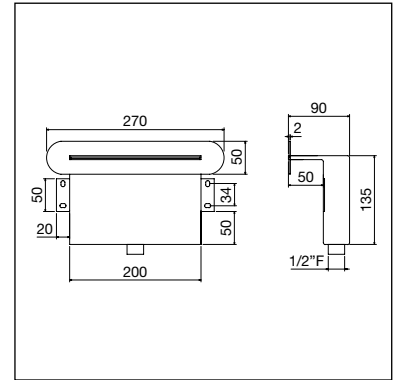

### CS12M

Bocca incasso a parete in acciaio inox,  
Mod. SECRET con placca quadra

Built-in wall mounted spout in stainless  
steel, Mod. SECRET with square  
rosette

AISI 304

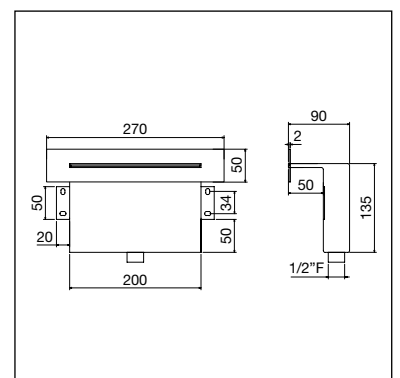

**Per predisposizione  
impianto idrico richiedere  
scheda tecnica**

**For water system set-up  
ask for installation manual**



## BOCCHE - CLASSIC SPOUTS - CLASSIC

### BE11M

Bocca a parete in acciaio inox,  
Mod. MINIMAL CLASSIC extra piatta

Wall mounted spout in stainless steel,  
Mod. MINIMAL CLASSIC extra thin

AISI 304

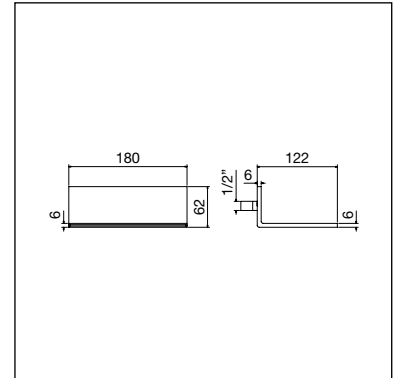

### BE12M

Bocca a parete in acciaio inox,  
Mod. CLASSIC

Wall mounted spout in stainless steel,  
Mod. CLASSIC

AISI 304

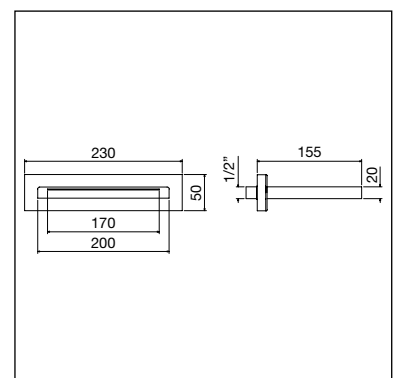

**Per predisposizione  
impianto idrico richiedere  
scheda tecnica**

**For water system set-up  
ask for installation manual**

## BOCCA - TOP CLASS SPOUT - TOP CLASS

### BE13V

Bocca a bordo vasca in acciaio inox,  
Mod. TOP CLASS

Poolside spout in stainless steel,  
Mod. TOP CLASS

AISI 304

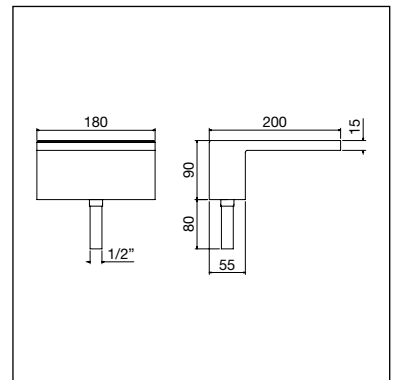



# SOFFIONI A SOFFITTO

Shower heads at ceiling



# SERIE WELLNESS - A SOFFITTO WELLNESS SERIE - AT CEILING

Soffione in acciaio inox con fissaggio a soffitto, telaio esterno H = 50 mm

Shower head in stainless steel with ceiling mounting, external frame H = 50 mm

AISI 304

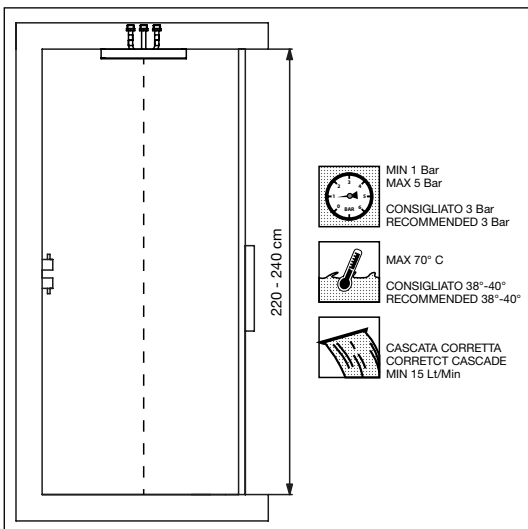
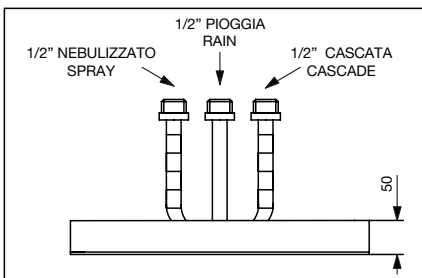

## EX50-11Q

Pioggia

Rain

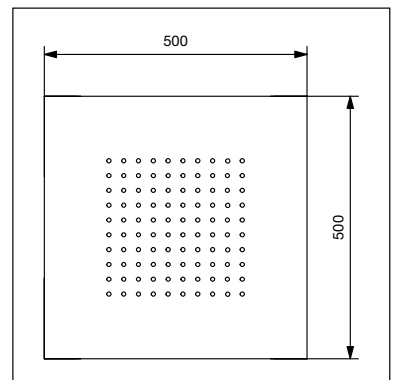

## EX50-13Q

Pioggia/Nebulizzato/Cascata

Rain/Spray/Cascade

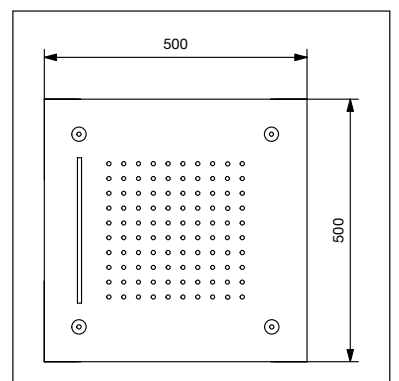

# SERIE WELLNESS - A SOFFITTO WELLNESS SERIE - AT CEILING

Soffione in acciaio inox con fissaggio a soffitto, telaio esterno H = 50 mm

Shower head in stainless steel with ceiling mounting, external frame H = 50 mm

AISI 304

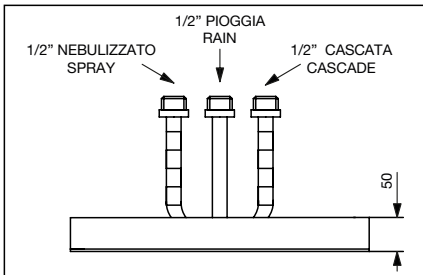

## EX70-11RT

Pioggia

Rain

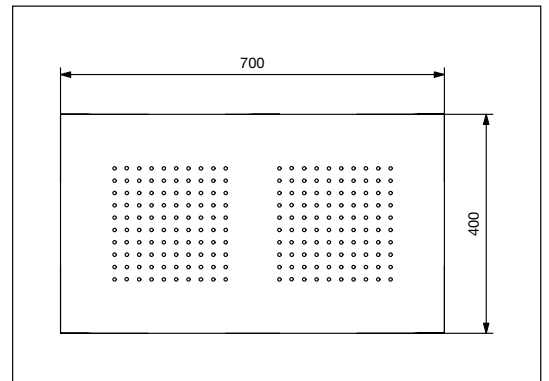

## EX70-13RT

Pioggia/Nebulizzato/Cascata

Rain/Spray/Cascade

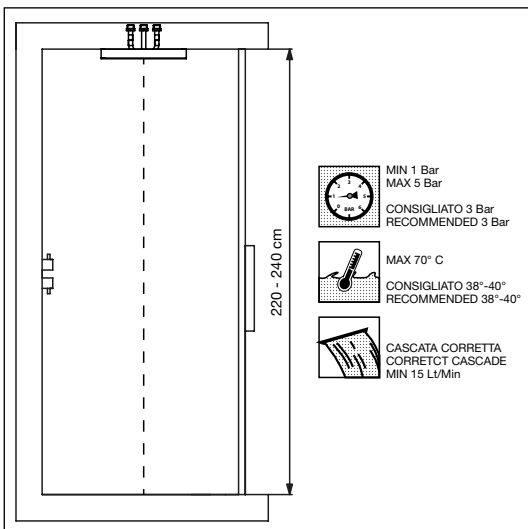
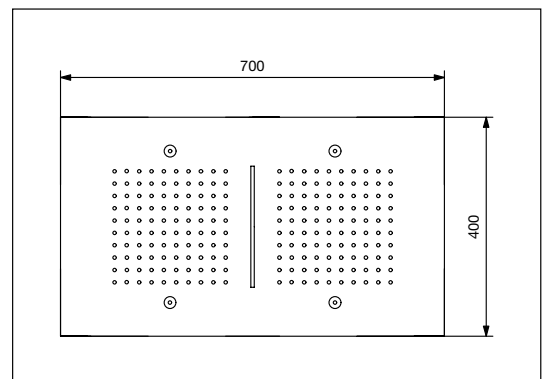

## SERIE WELLNESS - INCASSO WELLNESS SERIE - BUILT-IN

Soffione da incasso in acciaio inox senza telaio di supporto, completo di viterie di design e tasselli per il fissaggio

Built-in shower head in stainless steel without support frame, complete with design screws and ceiling plugs for fixing

AISI 304



**Sistema semplice di fissaggio**  
**Easy fixing system**

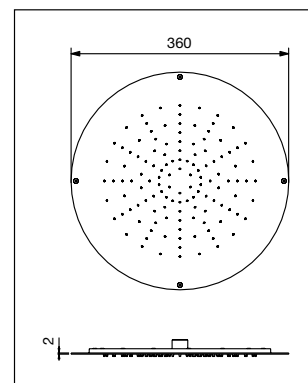
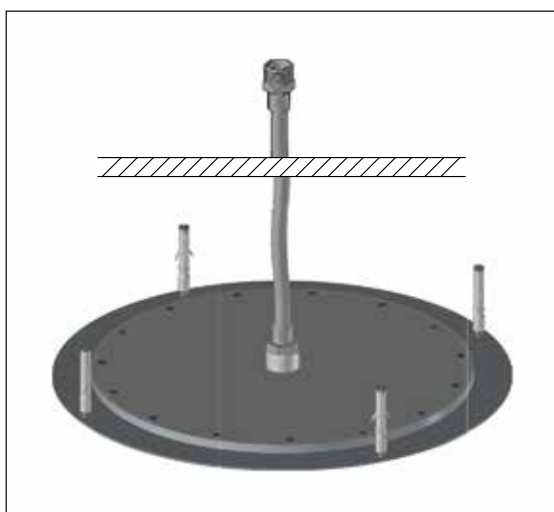

**V36-11TX**

Pioggia

Rain

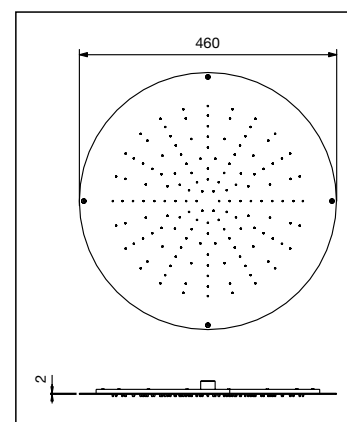

**V46-11TX**

Pioggia

Rain

## SERIE WELLNESS - INCASSO WELLNESS SERIE - BUILT-IN

Soffione da incasso in acciaio inox senza telaio di supporto, completo di viterie di design e tasselli per il fissaggio

Built-in shower head in stainless steel without support frame, complete with design screws and ceiling plugs for fixing

AISI 304



**Sistema semplice di fissaggio**  
**Easy fixing system**

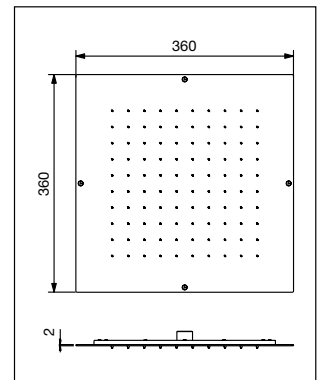
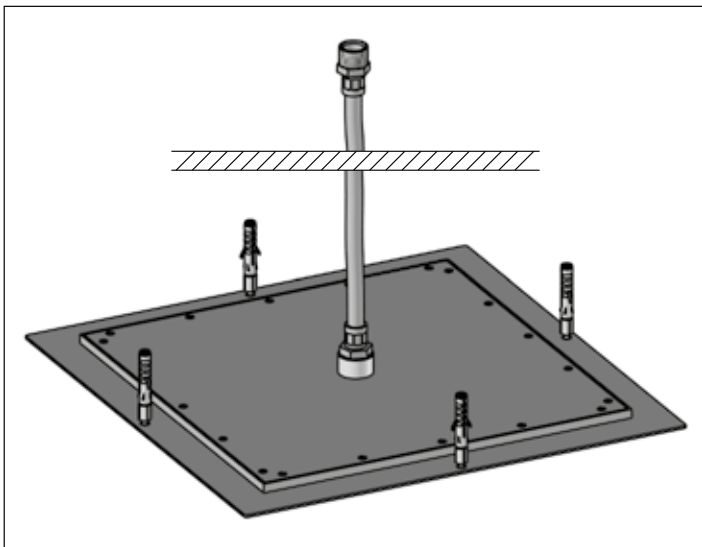

**V36-11QX**

Pioggia

Rain

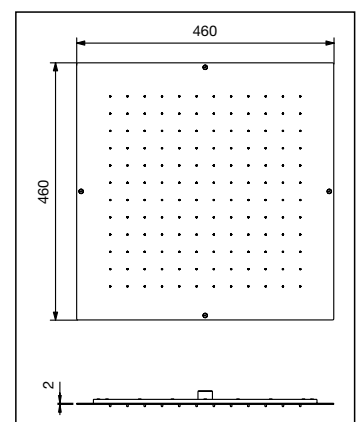

**V46-11QX**

Pioggia

Rain

# SERIE WELLNESS - INCASSO

## WELLNESS SERIE - BUILT-IN

Soffione da incasso in acciaio inox  
con telaio di supporto

Built-in shower head in stainless steel  
with support frame

AISI 304

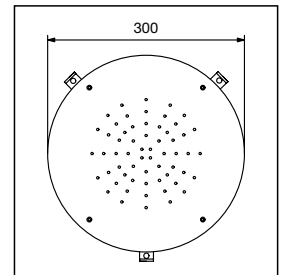
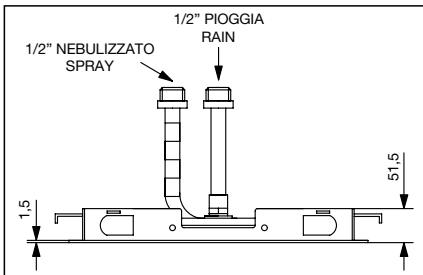
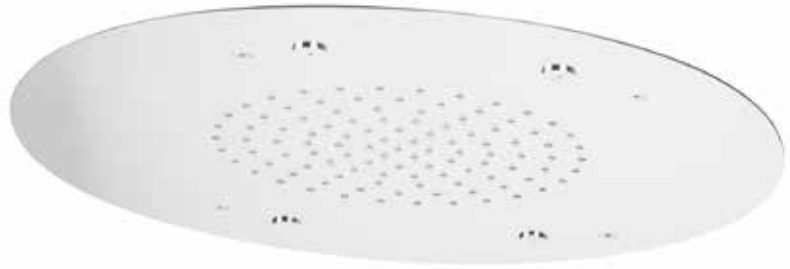

**V30-11T**

Pioggia

Rain

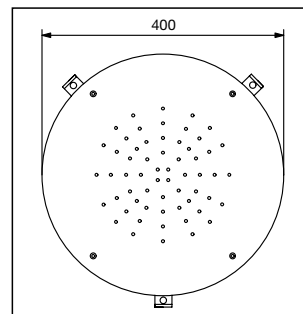

**V40-11T**

Pioggia

Rain

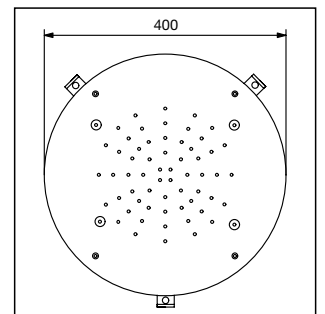

**V40-12T**

Pioggia/Nebulizzato

Rain/Spray

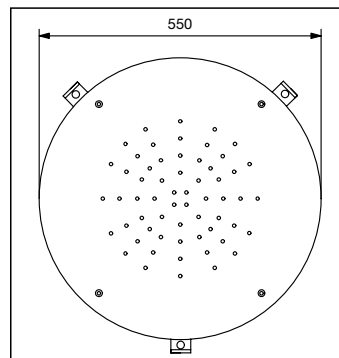
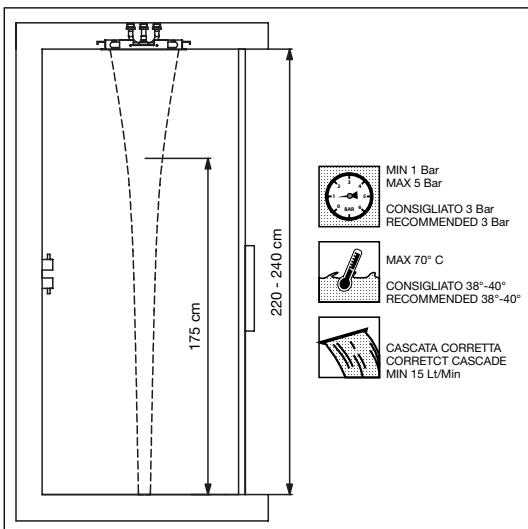

**V55-11T**

Pioggia

Rain

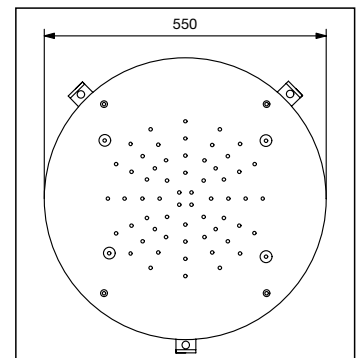

**V55-12T**

Pioggia/Nebulizzato

Rain/Spray

# SERIE WELLNESS - INCASSO

## WELLNESS SERIE - BUILT-IN

Soffione da incasso in acciaio inox  
con telaio di supporto

Built-in shower head in stainless steel  
with support frame

AISI 304

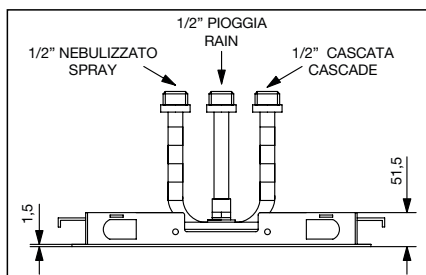

**Altre soluzioni disponibili su richiesta**  
**Other solutions available on request**

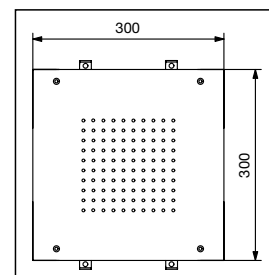

**V30-11Q**

Pioggia

Rain

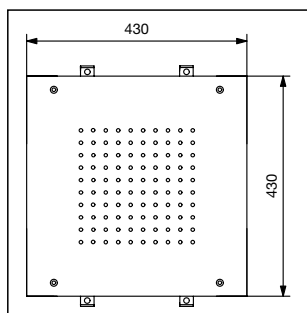

**V40-11Q**

Pioggia

Rain

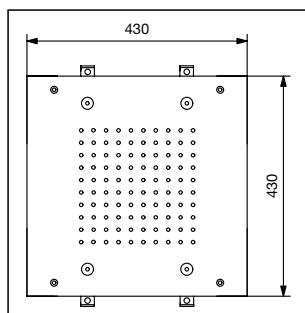

**V40-12Q**

Pioggia/Nebulizzato

Rain/Spray

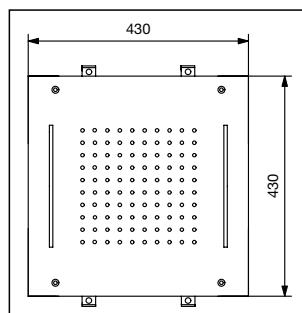

**V40-12Q.2C**

Pioggia/Cascata

Rain/Cascade

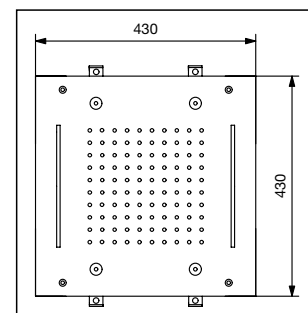

**V40-13Q**

Pioggia/Nebulizzato/Cascata

Rain/Spray/Cascade

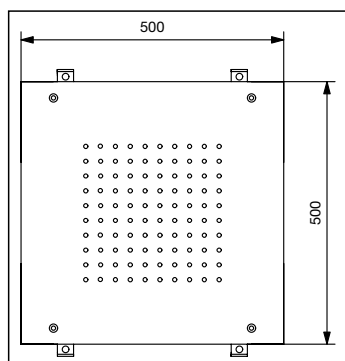

**V50-11Q**

Pioggia

Rain

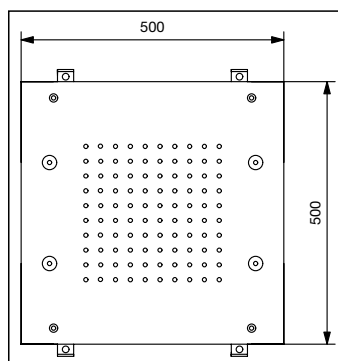

**V50-12Q**

Pioggia/Nebulizzato

Rain/Spray

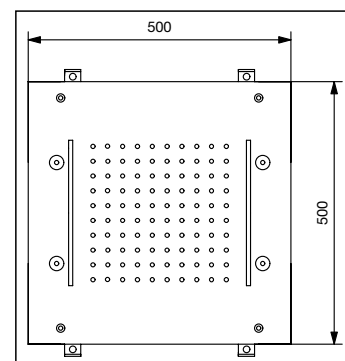

**V50-13Q**

Pioggia/Nebulizzato/Cascata

Rain/Spray/Cascade

# SERIE WELLNESS - INCASSO

## WELLNESS SERIE - BUILT-IN

Soffione da incasso in acciaio inox  
con telaio di supporto

Built-in shower head in stainless steel  
with support frame

AISI 304



**Altre soluzioni disponibili  
su richiesta**  
**Other solutions available  
on request**

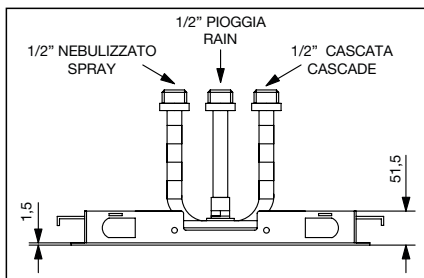

### V70-11RT

Pioggia

Rain

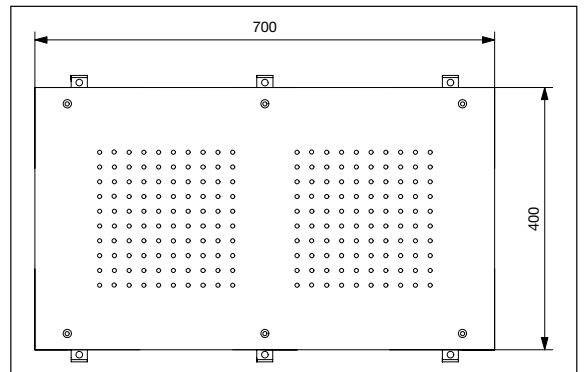

### V70-12RT

Pioggia/Nebulizzato

Rain/Spray

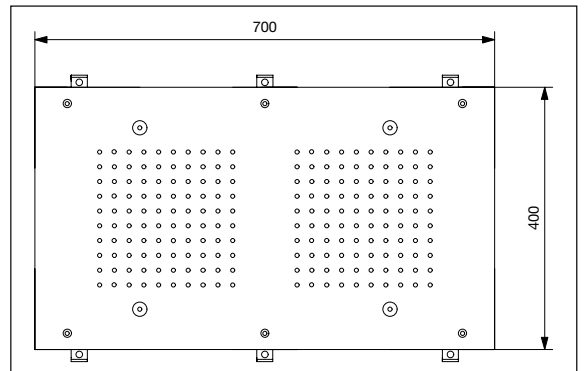

### V70-12RT.2C

Pioggia/Cascata

Rain/Cascade

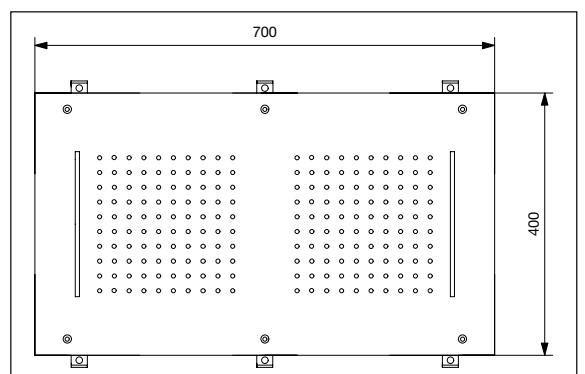

### V70-13RT

Pioggia/Nebulizzato/Cascata

Rain/Spray/Cascade

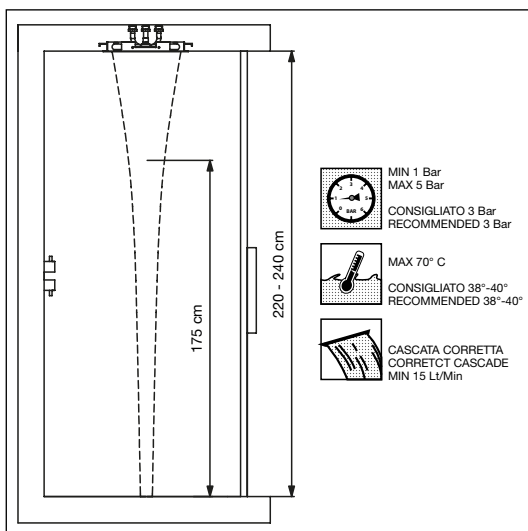
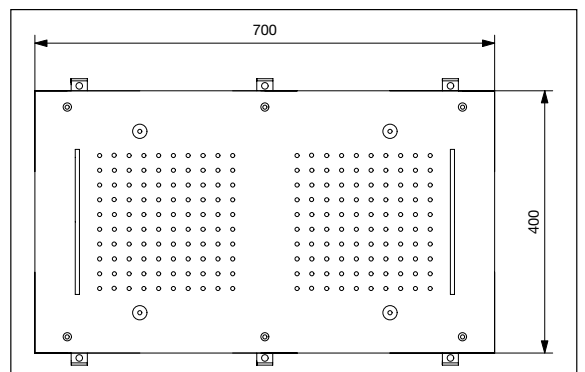

## VALVOLA DI SICUREZZA SAFETY VALVE



Tutti i nostri soffioni H2 sono dotati di limitatore di portata e guarnizione filtro ad incastro anti-caduta, già inseriti nel prodotto. SAFETY VALVE viene applicata al soffione per garantire integrità meccanica al prodotto evitando deformazioni, rotture e garantendo maggiore durata nel tempo.

Nonostante vengano applicate ai prodotti le migliori tecnologie tecniche e meccaniche e un materiale molto resistente come l'acciaio i prodotti necessitano comunque di una costante e quotidiana manutenzione.

Normalmente si possono avere delle lesioni al soffione dovute soprattutto alla scarsa manutenzione e pulizia del prodotto.

La scarsa pulizia degli ugelli di erogazione in silicone da parte dell'utilizzatore finale è la causa della maggior parte delle non conformità che si possono generare in questi prodotti.

SAFETY VALVE entra in funzione quando gli ugelli anticalcare in silicone vengono otturati da calcare o sedimenti presenti nell'acqua.

All'interno del soffione, si crea una contropressione di spinta dovuta alla riduzione dei fori di uscita, questo normalmente genera una forza di dilatazione, in quel momento SAFETY VALVE si apre e fa scaricare l'acqua dalla parte superiore del soffione obbligando l'utilizzatore ad effettuare la manutenzione ordinaria.

Questo sistema è molto utile anche per salvaguardare il prodotto dal colpo d'ariete se il prodotto subisce sbalzi di pressione la valvola si apre evitando il danneggiamento al prodotto. SAFETY VALVE entra in funzione anche in caso di manomissione del prodotto (rimozione del limitatore di portata).

Effettuando la pulizia del prodotto e reinserendo SAFETY VALVE si riporta nelle condizioni iniziali il prodotto.

All our shower-heads H2 are come fully provided with flow limiter and filter gasket, available right out of the box.

The SAFETY VALVE is applied to the shower head in order to guarantee mechanical integrity so to prevent deformations, damage and grant a longer life to the product.

Although the best technical and mechanical technologies and a very resistant material such as steel is used for our products, they nevertheless need regular maintenance.

Damages to the showerhead happens mostly due to inadequate maintenance and cleaning of the product.

Lacking of cleaning of the silicon nozzles by the end user is the cause of the majorities of non-conformities happening in these kind of products.

SAFETY VALVE comes into operation when the silicon anti-limescale nozzles get clogged by limestone or sediments in the water.

Inside a showerhead there is in this cases a counter-pressure due to the large number of plugged up nozzles that would normally result in a dilatation force that would damage it, instead SAFETY VALVE opens and let water pressure discharge from the top part of the showerhead requiring the user to performing the ordinary maintenance.

This system is also useful in preventing damages deriving from the so-called ram-effect; if the product undergoes surges in the water pressure the valves open preventing damages to the shower head. SAFETY VALVE also comes into operation in case of tampering with the product (removal of the flow limiter).

By cleaning the product and reinstalling the SAFETY VALVE the product is brought back to the initial conditions.



# CURA E GARANZIA DEI PRODOTTI

## PRODUCT CARE - WARRANTY

### CURA E MANUTENZIONE DEI PRODOTTI

Per evitare danni al vostro bagno e all'articolo acquistato è necessario seguire le seguenti raccomandazioni:

Spurgare l'impianto idrico prima di procedere con l'installazione del nuovo prodotto per eliminare ogni traccia di sedimento e/o corpo estraneo all'interno di esso.

Pulire periodicamente, se presenti, le testate di erogazione dell'acqua da eventuali depositi di calcare.

**Per la semplice pulizia delle parti metalliche è sufficiente utilizzare un panno morbido inumidito con acqua e sapone.**

Per evitare la formazione di macchie dovute alla presenza di calcare nell'acqua si consiglia di asciugare il prodotto con un panno morbido dopo ogni utilizzo.

**L'uso di detersivi contenenti: alcool, acido cloridrico, acido fosforico, candeggina, cloro e le polveri abrasive, possono danneggiare irreparabilmente il prodotto.**

L'installazione di un impianto di filtraggio e addolcitura dell'acqua migliora e prolunga la vita del prodotto e dell'impianto stesso.

### CONDIZIONI GENERALI DI GARANZIA

Tutti i prodotti sono coperti da due anni di garanzia contro i difetti o vizi di fabbricazione che ne determinano un cattivo funzionamento.

La garanzia non si applica in caso di danni provocati da incuria, uso o installazione non conformi alle istruzioni fornite e/o manomissioni del prodotto. Inoltre la garanzia non copre:

- Il deterioramento del prodotto dovuto alla normale e fisiologica usura per un utilizzo corretto
- I difetti causati da un uso improprio del prodotto (ad esempio i difetti causati da oggetti acuminati quali cacciaviti, pinze, punteruoli, coltelli oppure causati da deformazioni da pressione, da cadute e da urti)
- Vizi o difetti determinati dall'apertura, modifica o riparazione del prodotto da parte di soggetti diversi dalla ditta produttrice
- Vizi o difetti generati e/o determinati dall'esposizione del prodotto alla salsedine, ai raggi solari e ad agenti atmosferici
- Installazione e/o utilizzo diversi da quelli indicati dal manuale di installazione
- Errata predisposizione e realizzazione dell'impianto idrico
- Danni causati da depositi di calcare e/o altre impurità
- Impieghi di materiale di pulizia differenti da quelli precedentemente indicati

### CARE AND MAINTENANCE OF PRODUCTS

To avoid damage to your bathroom and to purchased item, it is necessary to follow below recommendations:

Thoroughly flush the water system before proceeding with the installation of the new product to eliminate any trace of sediment and/or foreign body inside it.

Periodically clean the nozzles, if present, from any scale deposits.

**To simply clean of metal parts, is necessary to use a soft dampened cloth with soap and water.**

To avoid the formation of stains due to the presence of limestone in the water it is recommended to dry the product with a soft cloth after each use.

**The use of detergents containing: alcohol, hydrochloric acid, phosphoric acid, bleach, chlorine and abrasive powders can irreparably damage the product.**

The installation of a filtering and water softening system improves and extends the life of product and of plumbing.

### GENERAL WARRANTY CONDITIONS

All products are covered by two-year warranty against defects of manufacturing or defects that cause malfunction.

The warranty does not apply in the event of damage caused by neglect, use or installation that it doesn't comply with the provided instructions and/or tampering with the product. Furthermore the warranty does not cover:

- Product deterioration due to normal and physiological wear and tear for correct use
- Defects caused by improper use of the product (for example, defects caused by sharp objects such as screwdrivers, pliers, awls, knives or caused by deformation from pressure, falls and shocks)
- Problems or defects caused by opening, modification or repair of product by anyone other than the manufacturer
- Problems or defects generated and/or determined by exposure of the product to salt, sunlight and atmospheric agents
- Installation and/or use other than those indicated in the installation manual
- Incorrect preparation or construction of water system
- Damage caused by deposits of limestone and/or other impurities
- Uses of cleaning materials different from those previously indicated

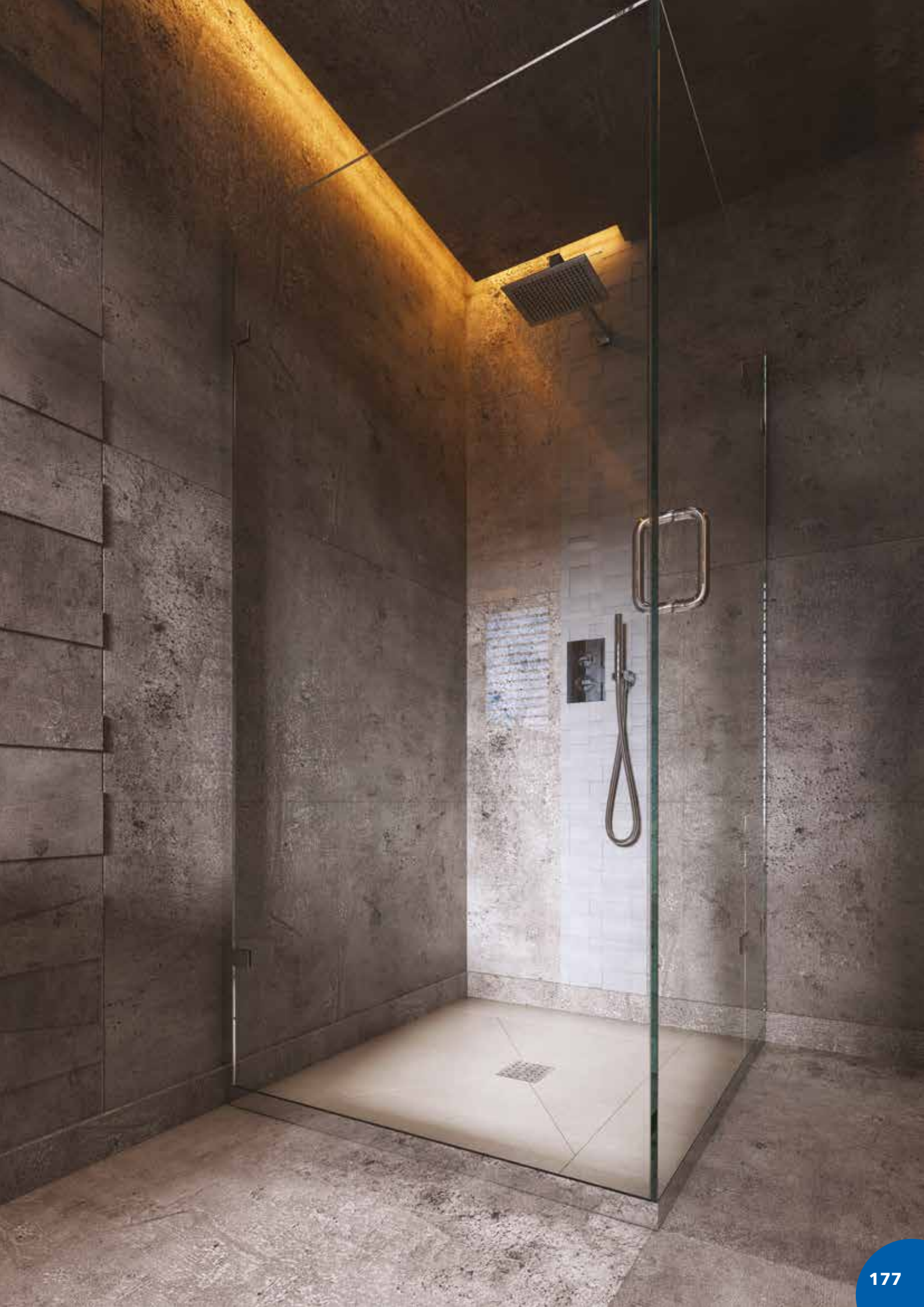







Le immagini di questo catalogo hanno valore puramente esemplificativo. VICARIO S.r.l. si riserva di apportare modifiche tecniche ed estetiche agli articoli illustrati senza obbligo di preavviso.

Images on this catalogue have only the set purpose of present the product. VICARIO S.r.l. reserves the right to make technical and aesthetic alterations on illustrated items without previous notice.



**Vicario S.r.l.**  
Via Stretta 5 - 28021 Borgomanero (NO) - Italy  
Tel. +39 0322 81887 - info@vicariosrl.com  
[www.vicariosrl.com](http://www.vicariosrl.com)

